

ELEVAH E6 MOVE PICKING

Max. working height	6 m
Max capacity	200 kg
Number of people	1
Use	Internal - External
A Closed machine height	1970 mm
B Min. height from the ground*	289 mm
C Maximum platform height	3980 mm
D	1100 mm
E Base overall dimensions	780 mm
F	1152 mm
G Cage dimensions	685 mm
H	600 mm
Machine weight	705 kg
Drive wheels dimension	Ø 186 x 60 mm
Swivel wheels dimensions	Ø 150 x 40 mm

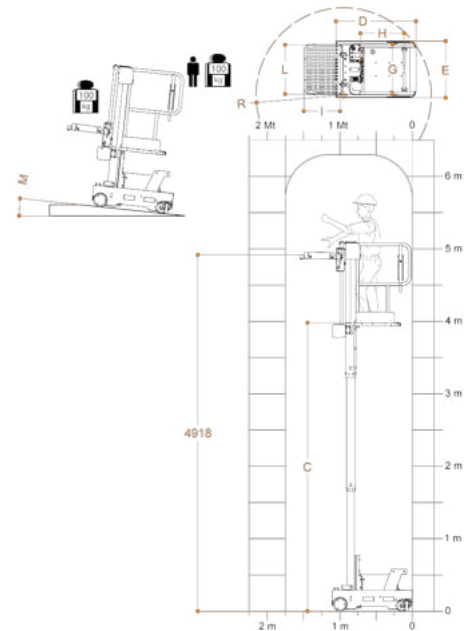
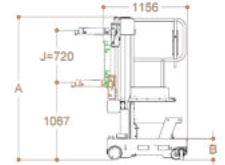

PICKING PLATFORM	
I	Dimensions
L	500 mm
	680 mm
Adjustment	Electrical
J Stroke	720 mm
Min. height from the ground	1067 mm
Maximum height from the ground	4918 mm
Capacity	100 kg

PERFORMANCE	
Power supply	Electrical 24 V
Batteries	2 Trojan Lead-Acid 12V 105 Ah
Battery charger	115V – 230V 50/60HZ
M Maximum climbing ability	15%
Climbing ability at height	2,5%
Internal turning radius	0
External turning radius	1250 mm
Max. speed (rising – descending)	0,2 m/s
Maximum speed (with basket on the ground)	5,5 km/h
N Maximum pressure for wheel at full load**	3,1 kN
Work cycles (with fresh batteries) ***	100

* There is an intermediate step.

** Maximum pressure whereas the weight of the platform plus the maximum load on the basket are completely distributed on one side of the platform (totally asymmetric load).

*** By work cycle we mean a self-propelled movement of 20 m with a full ascent to and descent from the maximum height and with adjustment of the loading platform.

CE Complies with European regulations for man-up forklift trucks. UNI EN ISO 3691-1.