

Sandvik DC700

Surface Top Hammer Drills



Sandvik DC700 is a hydraulic top hammer crawler drill.

DC700 is a robust drill in construction and therefore very well suited for work in demanding terrain. Design ensures reliable operation, easy trouble shooting and simple service and maintenance procedures. The optional feed-percussion follow-up in control system ensures maximum penetration rates and rock tool service life in all rock conditions. The cooling system on DC700 is designed for wide temperature range, from the extreme cold in the North to the heat of deserts.

Hole Diameter:	64...102 mm (2½...4")
Rock Tools:	38, 45 or 51 mm 1½", 1¾" or 2"
Rock Drill:	17,5 kW
Engine Output:	168 kW
Flushing Air:	8,1 m ³ /min, up to 10 bar
Production Capacity:	1000 - 2200 m ³ /8h
Total Weight	12 700 kg

STANDARD COMPONENTS

Rock drill	HL710
Chain feed	CF145 H12
Rod handler	RH714 including 1 set of wear parts
Boom	ZB 700 H, telescopic
Undercarriage	FL 6, oscillating
Powerpack	Diesel engine, hydraulic pumps and on-board compressor
Hydraulic system	Open center and load sensing
Control system	TDCD, direct hydraulic
Dust collection system	DC600H, hydraulic with movable suction head
Pressure gauge set	For accumulators
Reversing alarm	
Suction head	PE100S, movable
Working lights	5 pcs
Manuals	1 x paper copy 1 x CD-ROM (ToolMan)

SELECTION OF OPTIONS

1.	Movable control panel
2.	Spirit level angle indicator
3.	Mech. angle indicator MEC Angie
4.	Hose reel (not with 14' rods)
5.	Anti- freeze system for air lines
6.	Feed-percussion follow up
7.	Primary separator
8.	Flushing control automatics
9.	Shut down of suction for water holes
10.	Dustmizer
11.	Water injection system
12.	Guides for grousers
13.	Three bar grouser plates*)
14.	Towing hook
15.	Hydraulic rear ground support

THE JAWS FOR DRILL STEELS

Drill rod type	Drill rod diameter	Recommended hole diameter
Extension rods	38 mm (T38) 1½"	64...76 mm 2½"...3"
MF-rods	38 mm (T38) 1½"	64...76 mm 2½"...3"
Extension rods	45 mm (T45) 1¾"	76...89 mm 3"...3½"
MF-rods	45 mm (T45) 1¾"	76...89 mm 3"...3½"
MF-rods	51 mm (T51) 2"	89...102 mm 3½"...4"

Note: If several jaws selected please specify jaws assembled. DC700 with hose reel can only be used with 12' rods. 51 mm (2") extension rods only 5 + 1.

16.	Fuel powered heater for engine
17.	Electric fuel filling pump
18.	Grinder Sandvik RG420H
19.	Central lubrication system Sandvik
20.	Biodegradable hydraulic oil, Shell Naturelle HFE 46 or HFE 68
21.	Kit for alternative steels, each
22.	First service kit for DC 700
23.	Special tools for HL 710, field kit
24.	Security+ (Silver, Gold or Platinum)
25.	Extra manuals, price will be added according to pricing sheet
	*) Replaces standard component

COVERAGE AREA

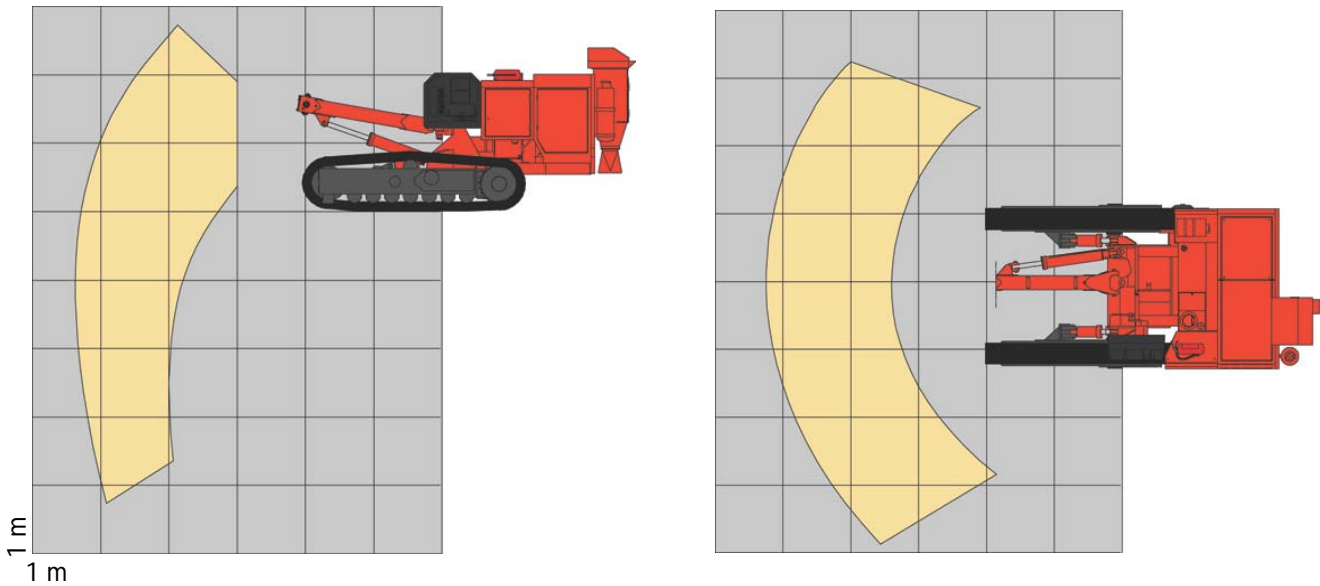

TRAMMING AND TRANSPORT DIMENSIONS

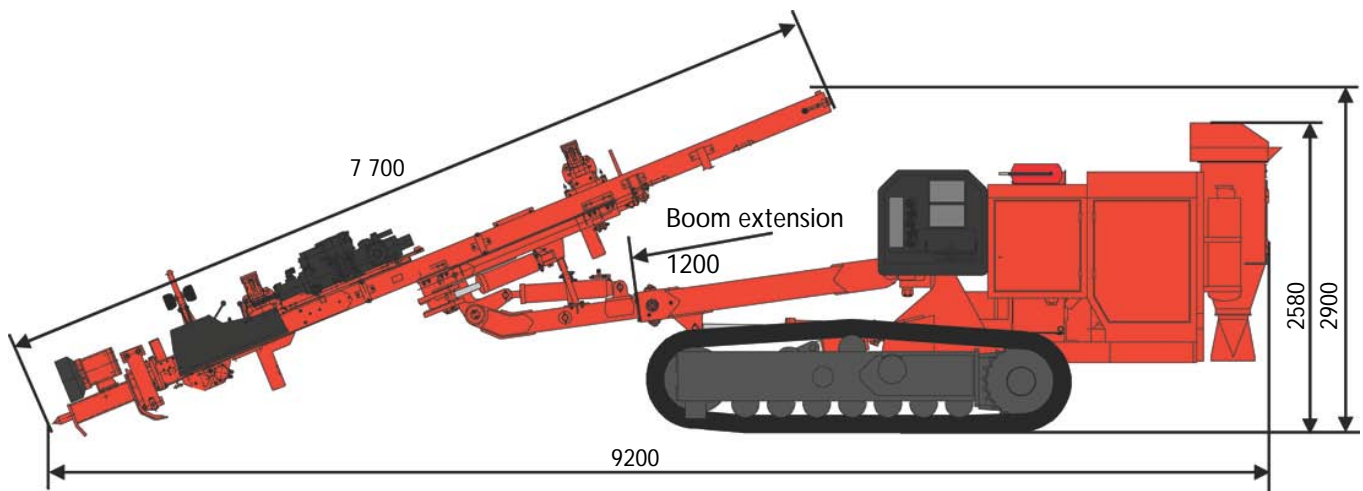

Weight (without options)	12 700 kg
Width	2 500 mm
Height	2 900 mm
Total length	9 200 mm