

# DPX-19812

## Perkins Generator

Prime: 290KW/363KVA

Standby: 320KW/400KVA

### Technical Data

Model		400kva
Prime power	kva	363
	kw	290
Standby power	kva	400
	kw	320
Rated voltage line to line	V	400
Rated current	A	523
Maximun sound level	dB@7m	75

### Engine-Perkins

Model		2206C-E13TAG2
Aspiration		In line, Turbo charged,air to air chargecooled
Fuel system		Direct injection
No. cylinders		6
Displacement	L	12,5
Bore*Stroke	mm	115x149
Compression ratio		16.3:1
Rated speed	r/min	1500
Governor		ECM
Engine size	mm	2410x1120x1725
Engine wet weight	kg	1478
Fire order		1-5-3-6-2-4
Start Motor	V	24
Rotation		Anti-clockwise, viewed on the flyweel

### Air inlet

Air inlet restriction	kpa	3,7
Max air restriction	kpa	6,35

### Fuel system

type of injection system		MEUI
fuel injector pressure		200MPa

## Fuel System

110% load(Standby power)	L/h	82
100% load(Prime power)	L/h	75
75% load(Prime power)	L/h	58
50% load(Prime power)	L/h	40
Fuel capacity for silent genset	L	580
Fuel capacity for open genset	L	580

## Lubrication System

Oil capacity	L	40
--------------	---	----

## Cooling System

Total coolant capacity	L	51,4
------------------------	---	------

## Standard Features

Engine(Perkins ENGINE)	●
Radiator 50°C max,fans are driven by belt	●
24V charge alternator	●
Alternator: single bearing alternator IP23	●
insulation class H/H	●
Standard auto control system	●
Main line circuit breaker / ACB	●
Base fuel tank	●
24V batteries, rac and cable	●
Exhaust system(Ripple flex exhaust pipe)	●
Exhaust siphon, flange, muffler	●
User manual	●
Battery charge	●

## Options

Water heater	○
Alternator heater	○
One set of air filter, fuel filter, oil filter	○
PMG	○
Water oil separator	○
Daily fuel tank	○
Remote control panel	○
Automatic transfer switch/ATS	○
Switch box	○

Standard: ●

Options: ○

## Alternator

Model		TAL-A46-H
Alternator Brand		Leroy Somer
Phase		3
Voltage	V	400
Wiring Type		6 wires
Bearing		1
Power factor		0,8
Frequency	Hz	50
Prime power	KVA	365
Exciter Type		Brushless, self-excitation
Voltage regulation	%	±0.5
Protection Grade		IP 23
Insulation grade		H

## Controller-Deepsea

Model	DSE 7320
7 configurable digital inputs	
Built-in governor and AVR control	
Base load (kW export) functionality	
Mains (utility) de-coupling protection	
Generator power (kW, kVA) monitoring	
Overload (kW & kV Ar) protection	
Emergency stop	
Start failure	



## Unit Dimensions(Basic unit)

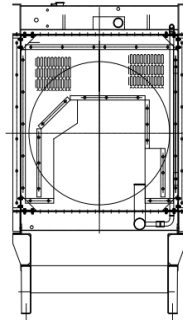
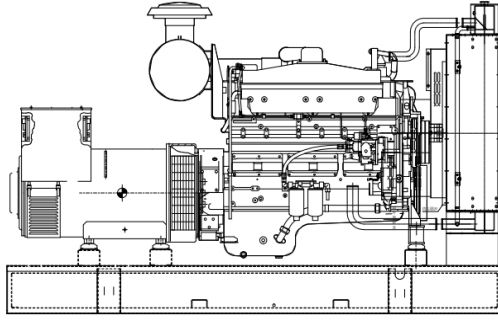

### Open Type

L*W*H	mm	3150*12300*1900
Weight	kg	3000

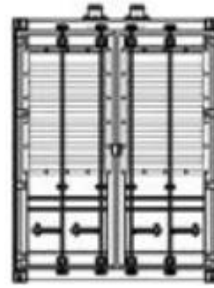
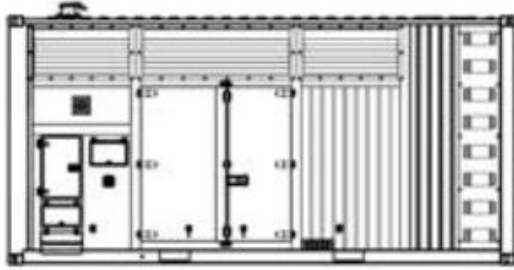

### Silent Type

L*W*H	mm	4150x1550x2300
Weight	kg	4000

## Warranty

### Perkins Engine

12 months from date of purchase or 1000 hours.

### Generator

12 months from date of purchase or 1000 hours

(whichever comes first).