

TECHNICAL DATA

SINGLE DRUM ROLLERS

BW 213 D-5, BW 213 DH-5, BW 213 PDH-5

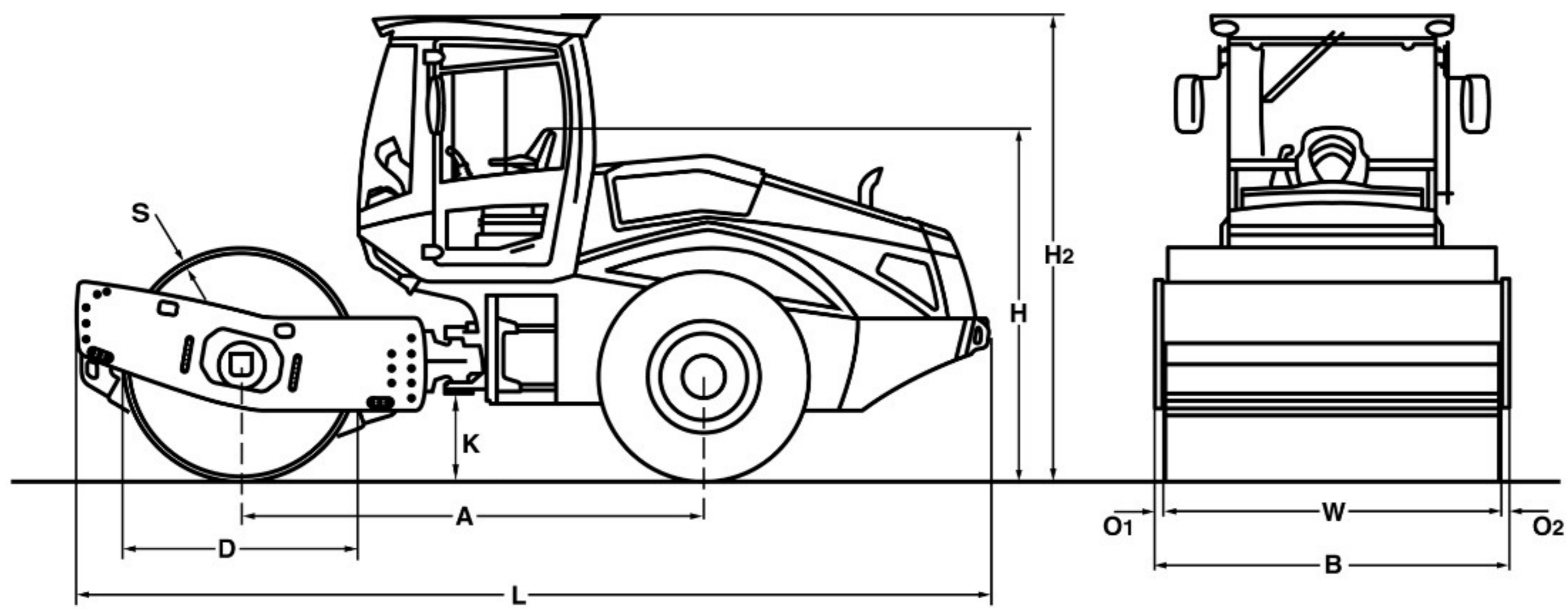



Dimensions in mm

	A	B	D	H	H2	K	L	O1	O2	S	W
BW 213 D-5	2975	2270	1500	2250	2990	490	5870	70	70	30	2130
BW 213 DH-5	2975	2270	1500	2250	2990	490	5870	70	70	30	2130
BW 213 PDH-5	2975	2270	1480	2250	2990	490	5870	70	70	25	2130

Shipping dimensions in m3

	without ROPS	with ROPS
BW 213 D-5	29,981	39,841
BW 213 DH-5	29,981	39,841
BW 213 PDH-5	29,981	39,841

Machine type	Compaction output (m3/h)			
	Rock fill	Gravel, sand	Mixed soil	Silt, clay
BW 213 D-5	470-940	300-600	240-480	120-240
BW 213 DH-5	530-1060	360-720	270-540	180-360
BW 213 PDH-5	530-1060	360-720	270-540	210-420

Machine type	Compacted layer thickness (m)			
	Rock fill	Gravel, sand	Mixed soil	Silt, clay
BW 213 D-5	0,80	0,50	0,40	0,20
BW 213 DH-5	0,80	0,50	0,40	0,25
BW 213 PDH-5	0,90	0,60	0,50	0,30

Technical Data**BOMAG
BW 213 D-5****BOMAG
BW 213 DH-5****BOMAG
BW 213 PDH-5****Weights**

Grossweight	kg	14.800	15.800	14.870
Operating weight CECE w. ROPS-cabin	kg	12.600	12.720	13.830
Axle load, drum CECE	kg	7.550	7.560	8.670
Axle load, wheels CECE	kg	5.050	5.160	5.160
Static linear load CECE	kg/cm	35,4	35,5	

Dimensions

Working width	mm	2.130	2.130	2.130
Track radius, inner	mm	3.680	3.680	3.680

Driving Characteristics

Speed (1)	km/h	0- 5,0		
Speed (2)	km/h	0- 6,0		
Speed (3)	km/h	0- 8,0		
Speed (4)	km/h	0- 11,0		
Speed	km/h		0- 12,0	0- 12,0
Max. gradeability without/with vibr. ...	%	45/43	60/57	62/60

Drive

Engine manufacturer		Deutz	Deutz	Deutz
Type		TCD 3.6 L4	TCD 4.1	TCD 4.1
Emission stage		Stage V	Stage V / TIER4f	Stage V / TIER4f
Exhaust gas aftertreatment		DOC+DPF+SCR	DOC+DPF+SCR	DOC+DPF+SCR
Cooling		Liquid	Liquid	Liquid
Number of cylinders		4	4	4
Performance ISO 3046	kW	95,0	115,0	115,0
Performance SAE J 1995	hp	128,0	155,0	155,0
Speed	min-1	2.000	2.100	2.100
Fuel		Diesel	Diesel	Diesel
Electric equipment	V	12	12	12
Drive system		hydrost.	hydrost.	hydrost.
Drum driven		standard	standard	standard

Drums and Tyres

Number of pad feet				150
Area of one pad foot	cm ²			137
Height of pad feet	mm			100
Tyre size		23.1-26 12PR	23.1-26 12PR	23.1-26 12PR

Brakes

Service brake		hydrost.	hydrost.	hydrost.
Parking brake		hydromec.	hydromec.	hydromec.

Steering

Steering system		oscil.artic.	oscil.artic.	oscil.artic.
Steering method		hydrost.	hydrost.	hydrost.
Steering / oscillating angle +/-	grad	35/12	35/12	35/12

Exciter system

Drive system		hydrost.	hydrost.	hydrost.
Frequency	Hz	30/34	30/34	30/34
Amplitude	mm	2,10/1,10	2,10/1,10	1,70/0,90
Centrifugal force	kN	285/196	285/196	285/194
Centrifugal force	t	29,1/20,0	29,1/20,0	29,1/19,8

Capacities

Fuel	l	250,0	250,0	250,0
------------	---	-------	-------	-------

Technical modifications reserved. Machines may be shown with options.

Standard Equipment

- BOMAG ECOMODE
- Warning, information and operation displays with LCD
- Hydrostatic travel and vibration drive
- Hydrostatic articulated steering
- Articulated joint lock
- Rear axle with twin spring accumulator brakes
- Self locking differential
- Warning horn
- Single lever control for travel and vibration
- Seat with arm rest and adj. for position and height
- 2 Scrapers
- Emergency STOP
- Back-up alarm
- Working lights front / rear
- Double pump system for travel drive (DH/PDH)
- Tractor tires (PD)
- Loading mode
- Battery disconnect switch

Optional Equipment

- * ROPS/FOPS cabin with seat belts
 - Sliding window
- ROPS/FOPS with safety belt
- Air condition
- Rearview camera
- ECONOMIZER
- TERRAMETER
- BOMAG ECOSTOP
- BOMAG TELEMATIC POWER
- Padfoot segment kit (D/DH)
- Radio (Bluetooth)
- Indicator and hazard lights
- Special painting
- Rotary beacon
- Pre start cabin heating
- Environmentally compliant hydraulic oil
- Comfort package: Adjustable seat and adjustable steering column
- Measuring- and machine data interface for third-party suppliers
- Blade (DH/PDH)
- LED Working lights (Cabin)
- Reversing alarm buzzer with broad band audio

* Standard delivery with CE conformity
(valid within European Union)#72

