

# RTH

# 6.31



CONSTRUCTION



LOGISTICS

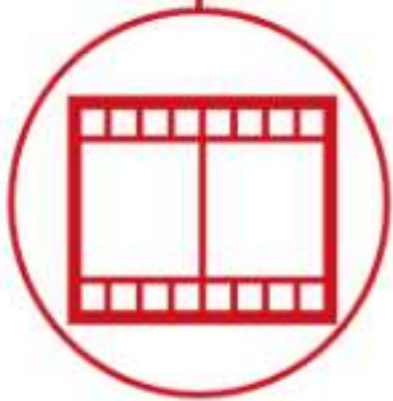

EVENTS AND  
FILM



FORESTRY



RTH

6.31



**CAB**

Best-in-class  
safety and visibility



**PERFORMANCE**

Unrivalled lifting  
performance



**LOAD LIVE DIAGRAM**

Three real-time dynamic  
load charts

# RTH 6.31

## DIMENSIONS (mm)

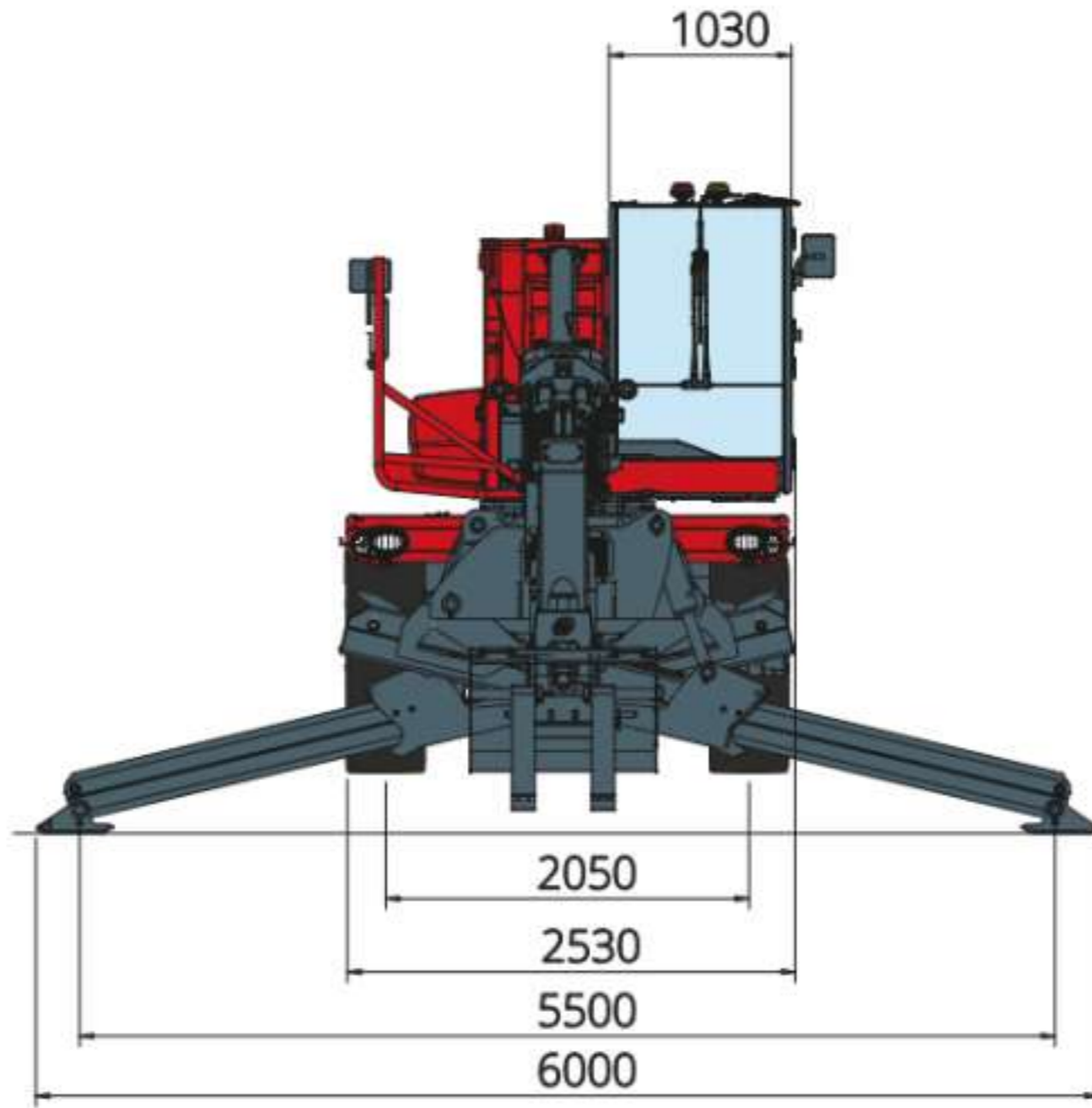

**FRONT**  
view

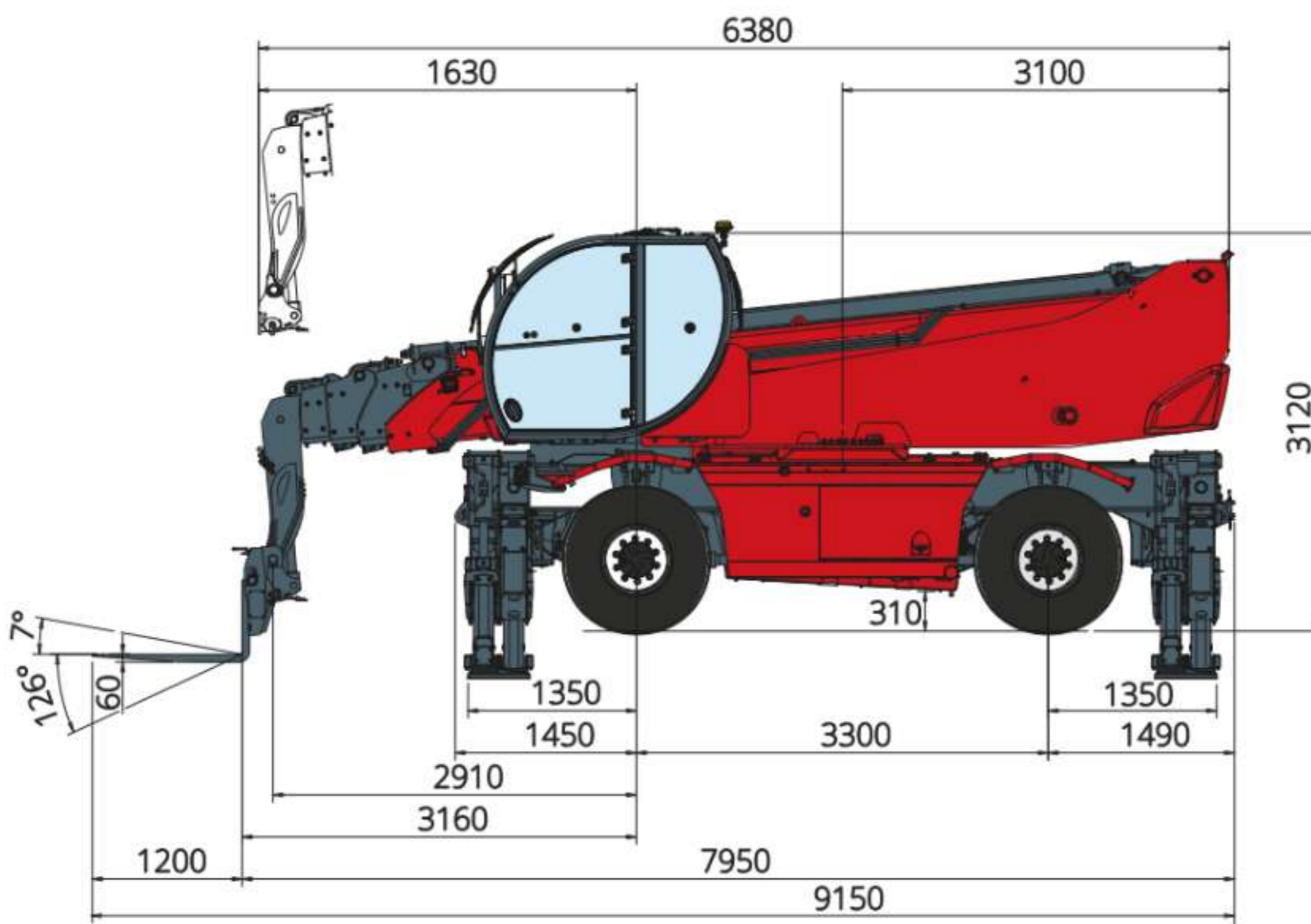

**SIDE**  
view

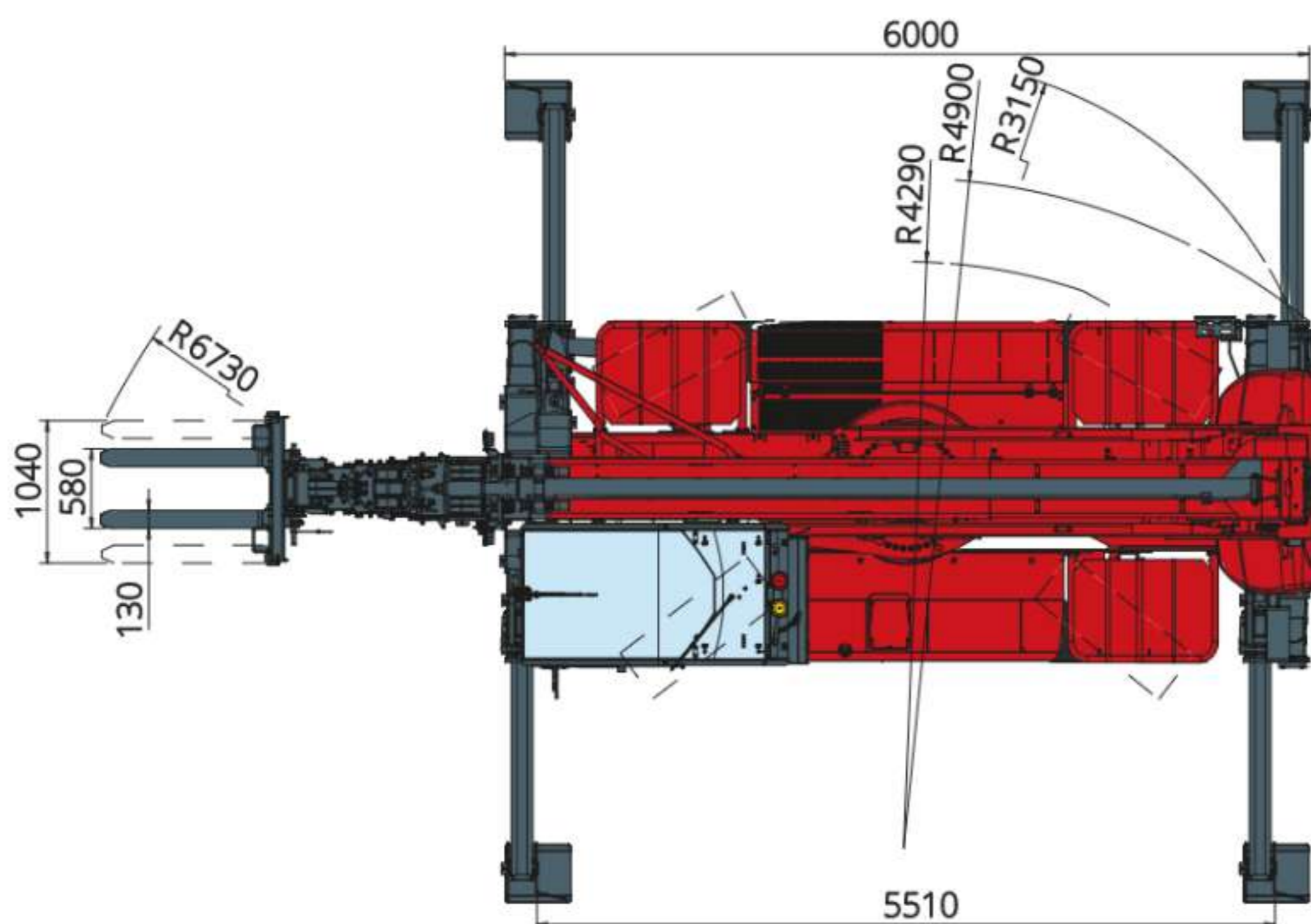

**TOP**  
view

Load chart with  
**FULLY EXTENDED STABILISERS (360°)**  
 ATT-03-004

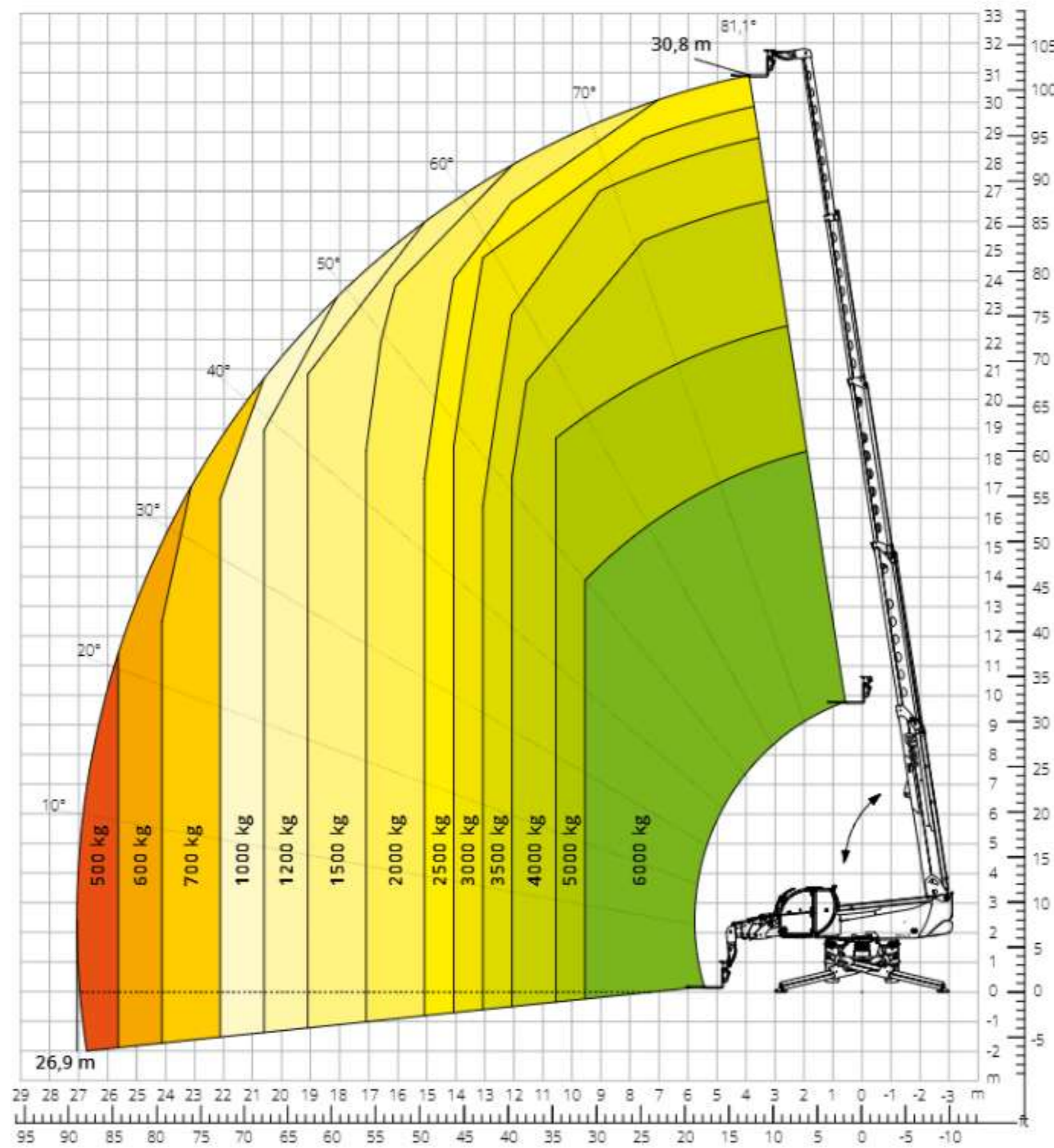

Load chart  
**FRONT ATTACHMENT ON TYRES**  
 ATT-03-004

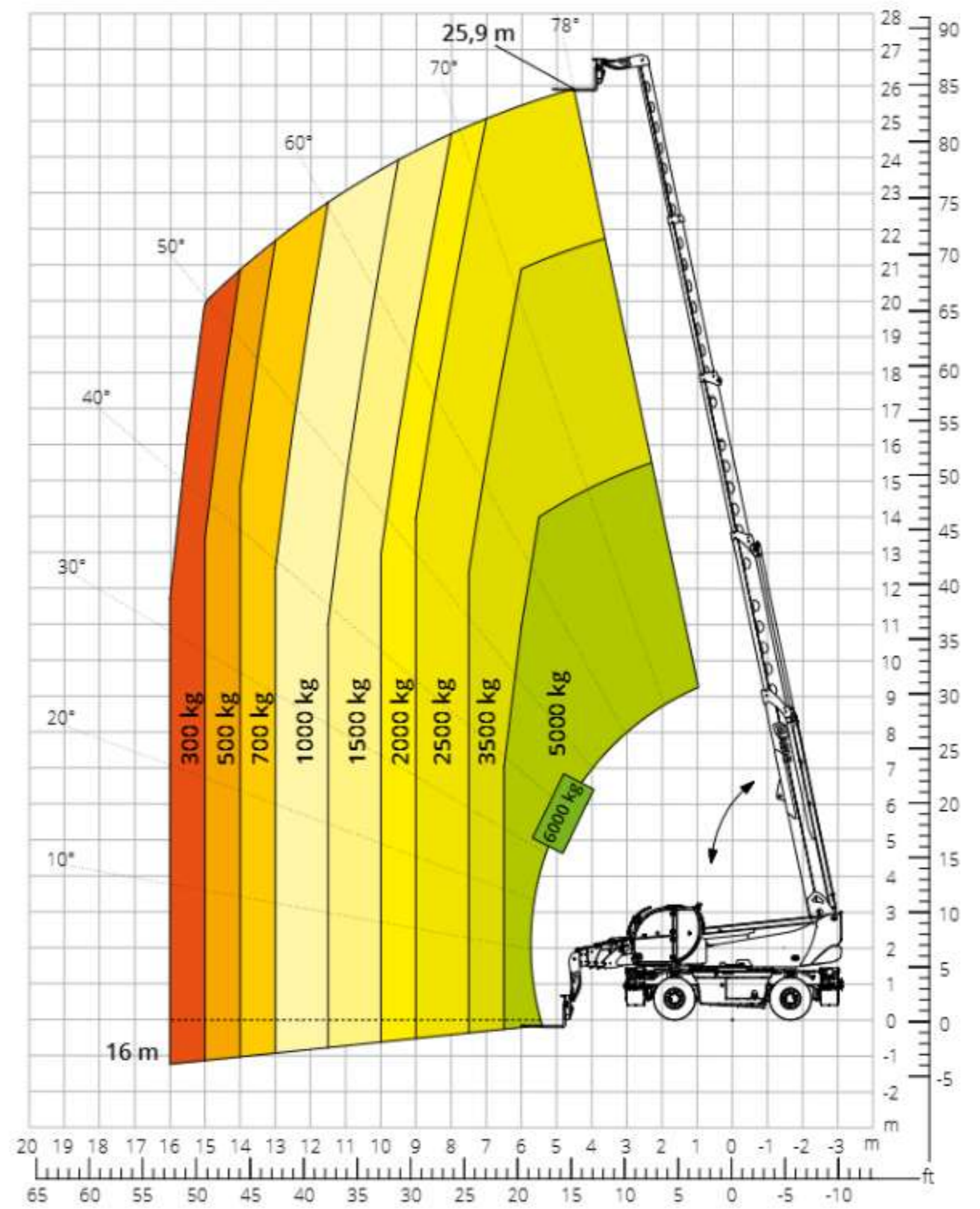

Load chart with  
**WINCH, 3,500 kg**  
 ATT - 02 - 002

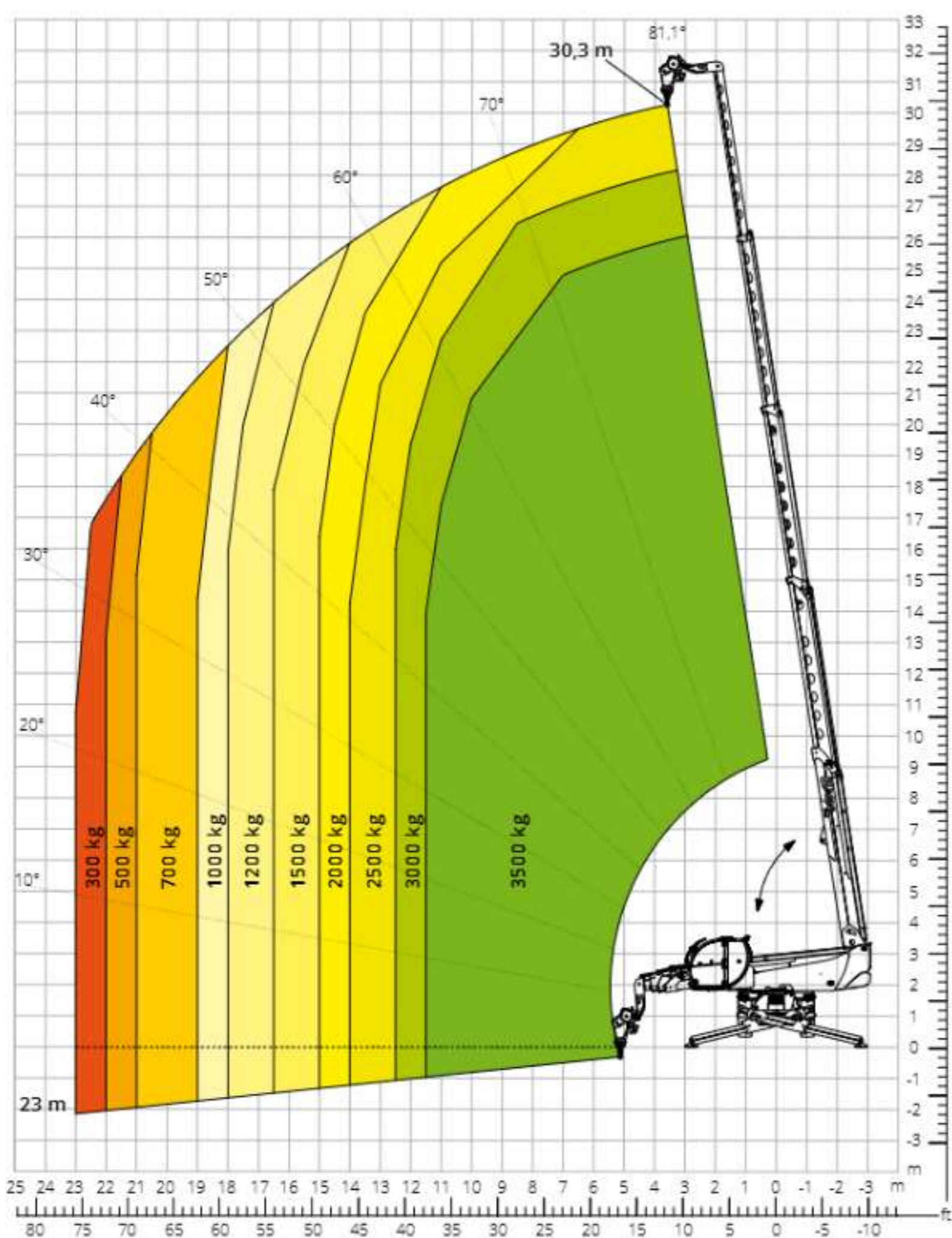

Load chart with  
**WINCH, 6,000 kg**  
 ATT - 02 - 004

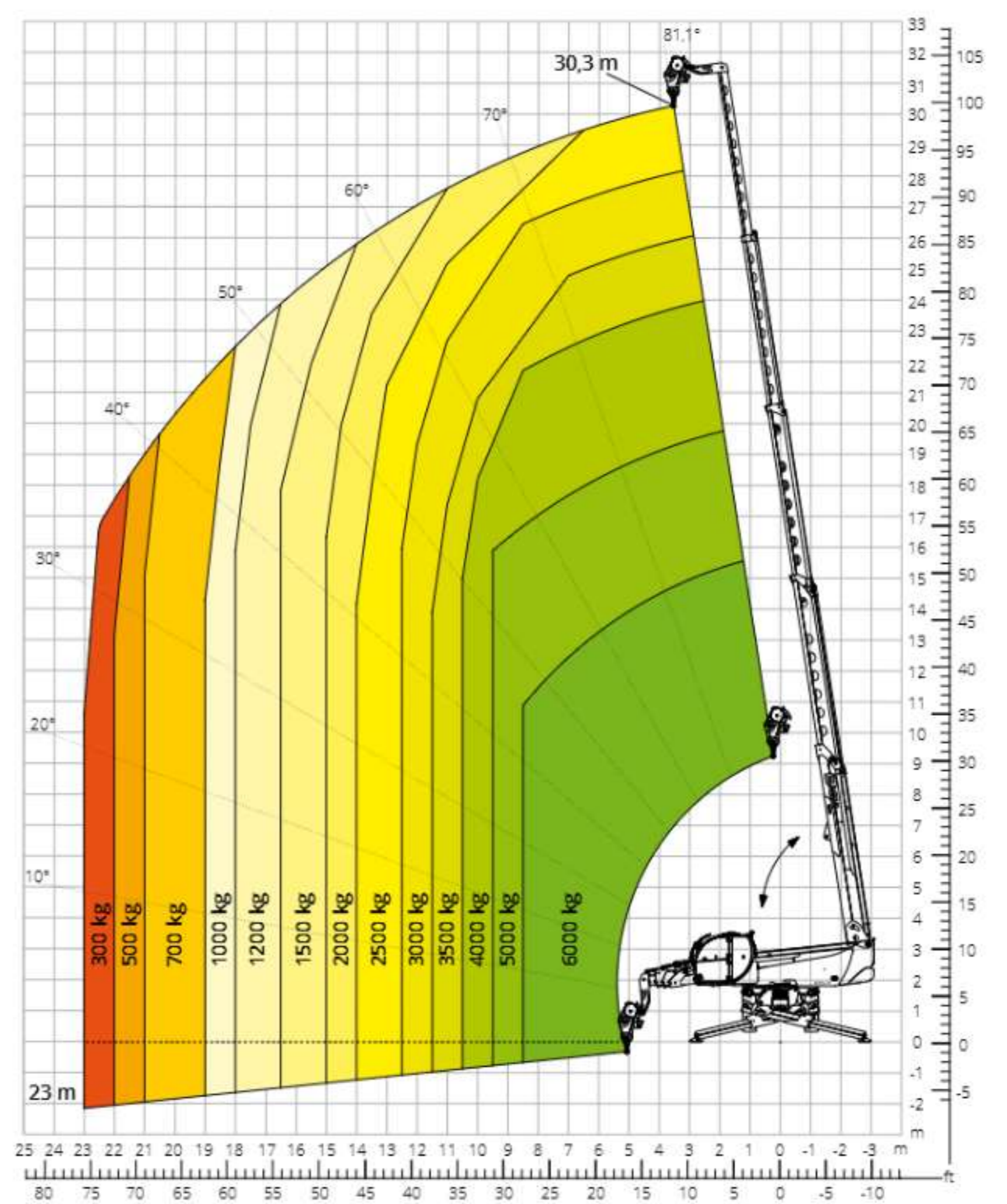

Load chart with  
**JIB WITH WINCH, 1,500 kg**  
 ATT - 04 - 011

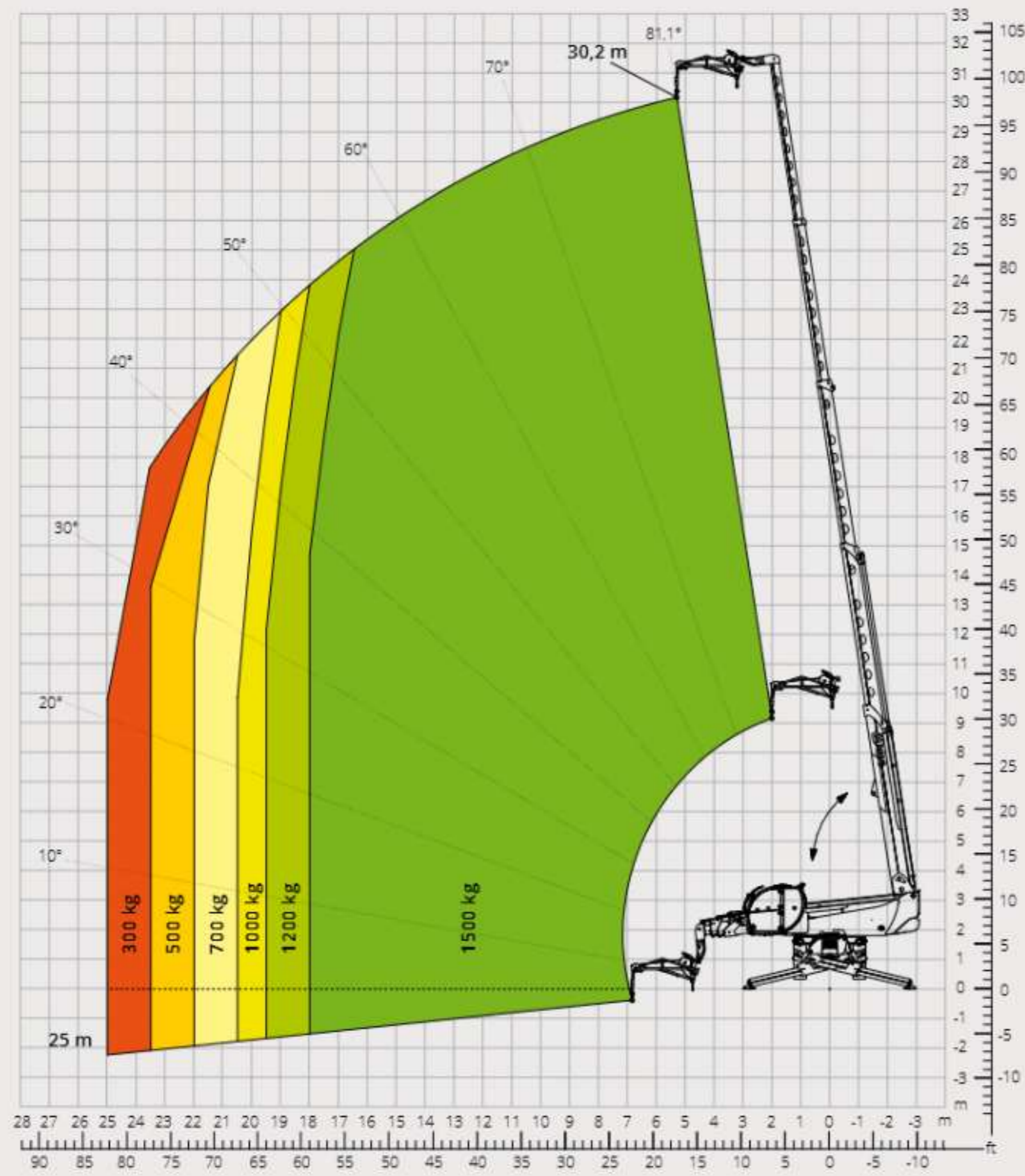

Load chart with  
**JIB WITH WINCH, 2,000 kg**  
 ATT - 04 - 015

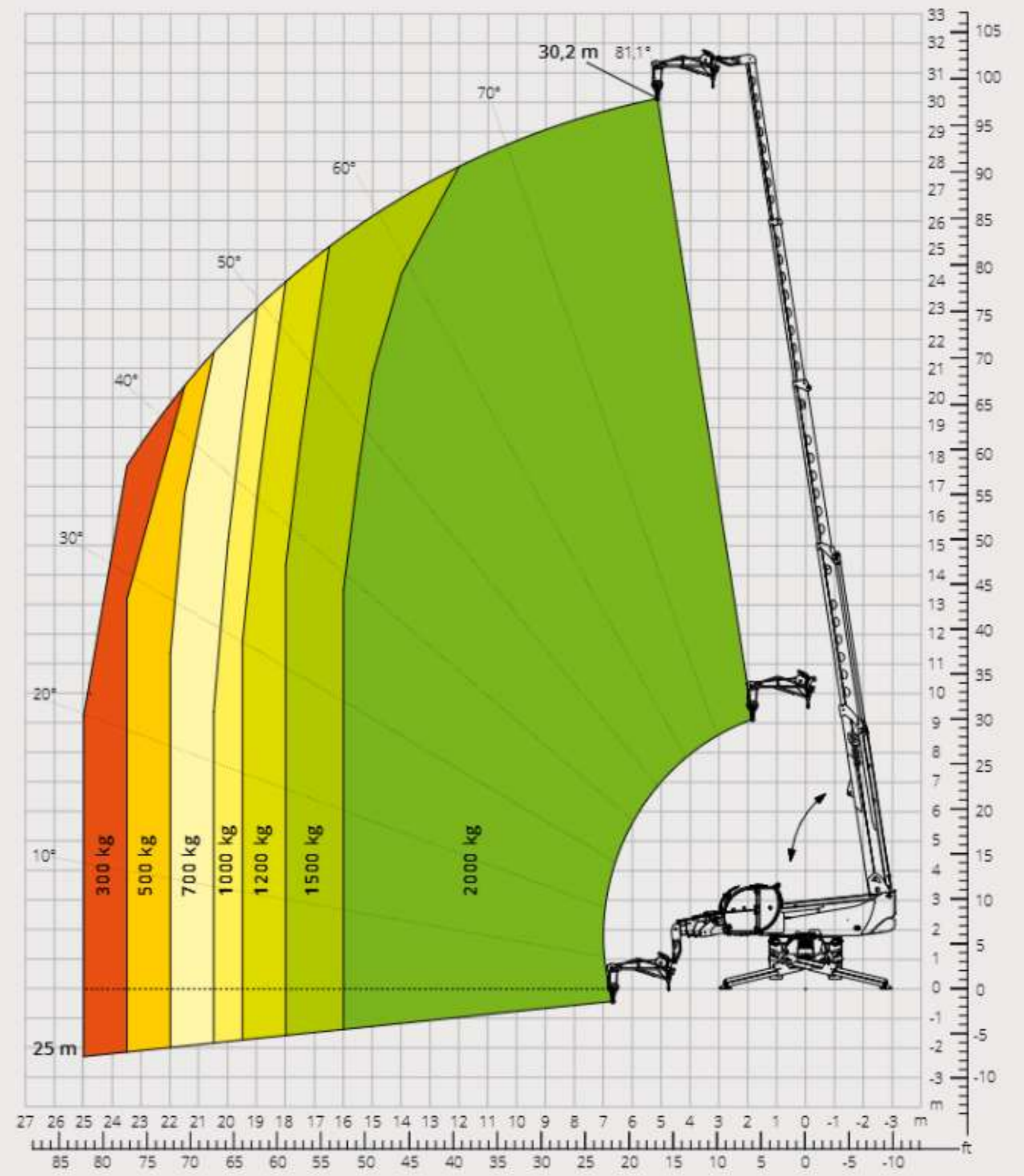

Load chart with  
**JIB WITH WINCH, 3,000 kg**  
 ATT - 04 - 019

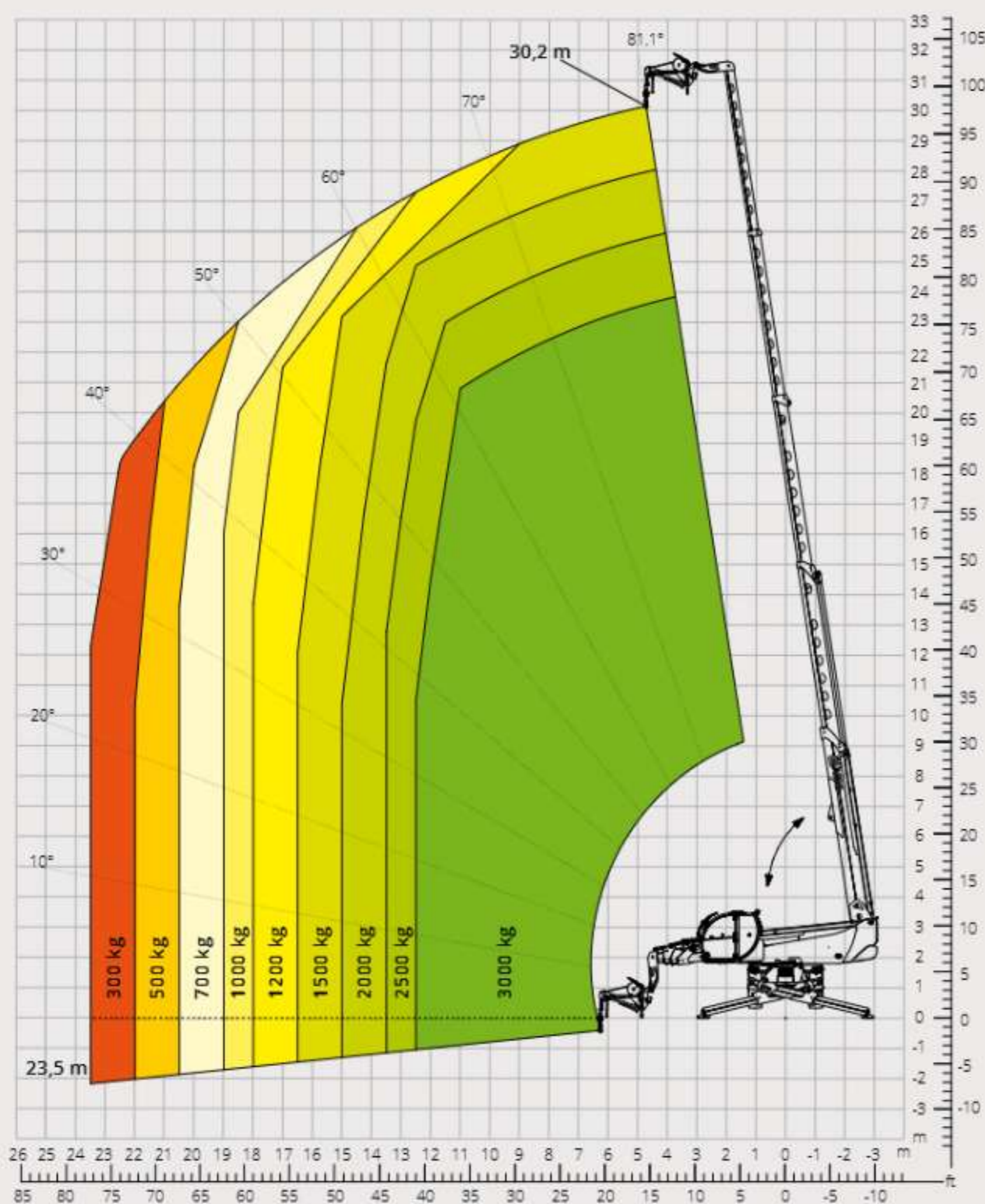

Load chart with  
**JIB, 2,000 kg**  
 ATT - 04 - 013

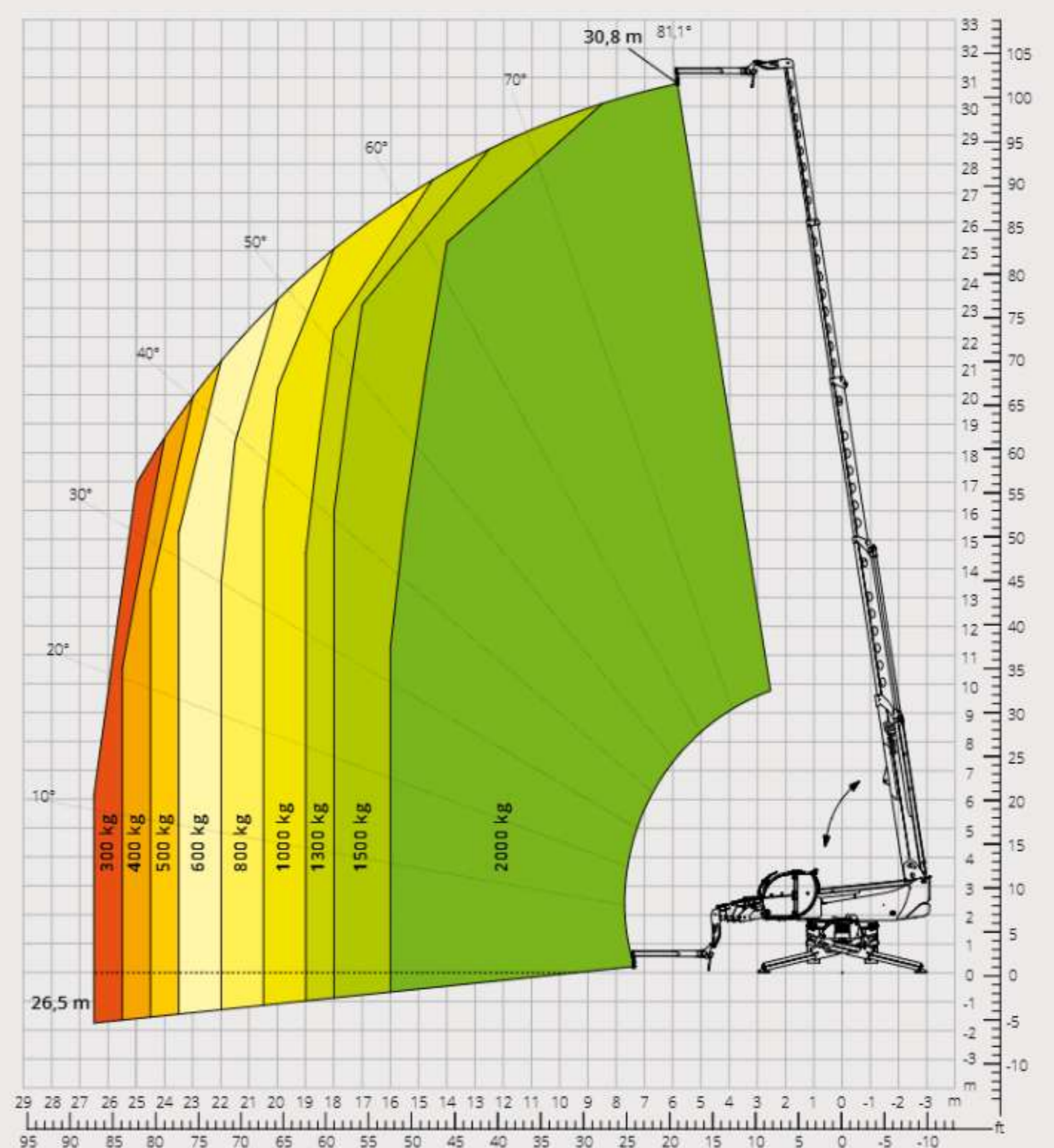

Load chart with  
**HOOK, 6,000 kg**  
ATT - 05 - 001

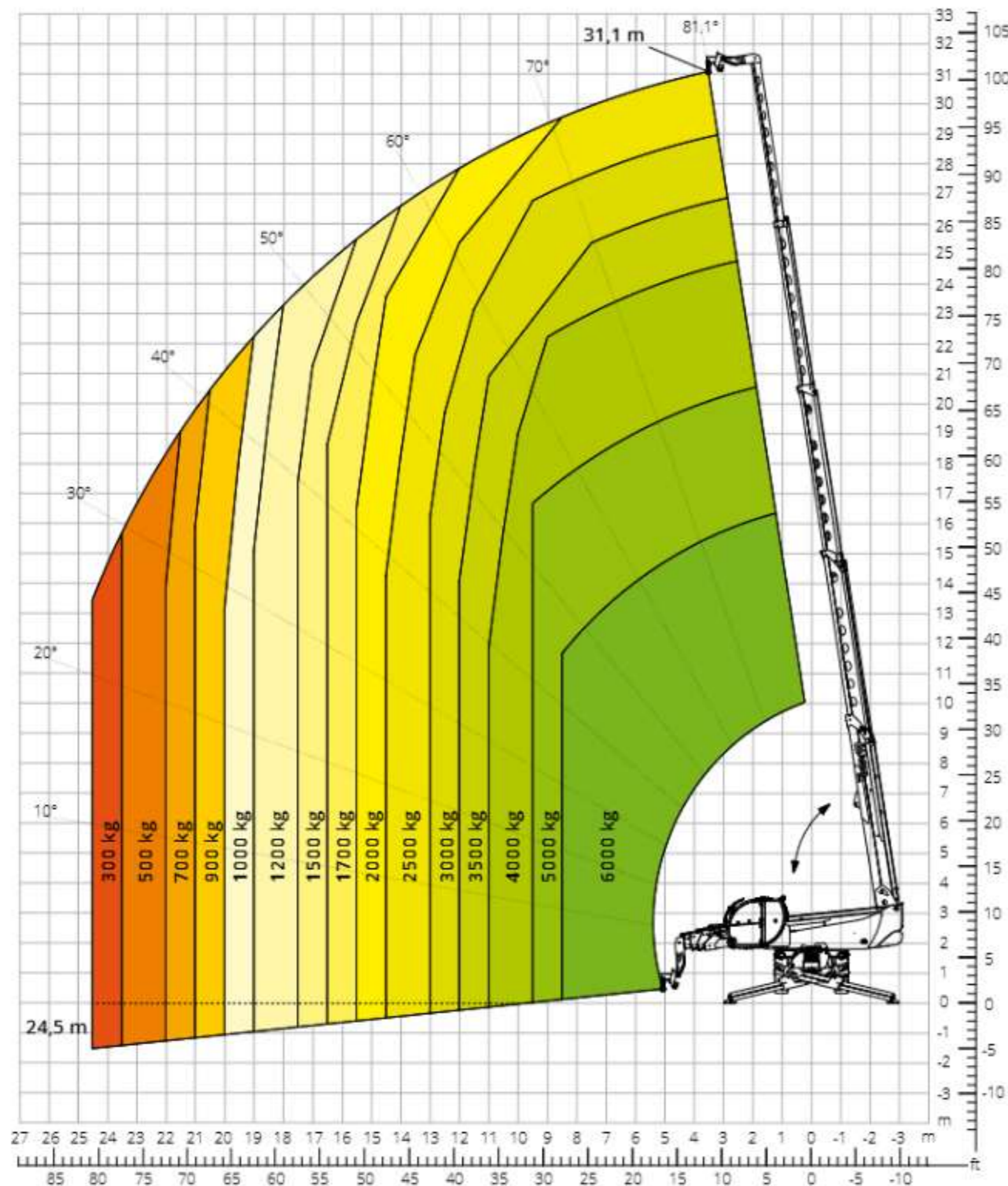

Load chart with  
**ROTATING EXTENDABLE PLATFORM, 500 kg**  
ATT - 01 - 007

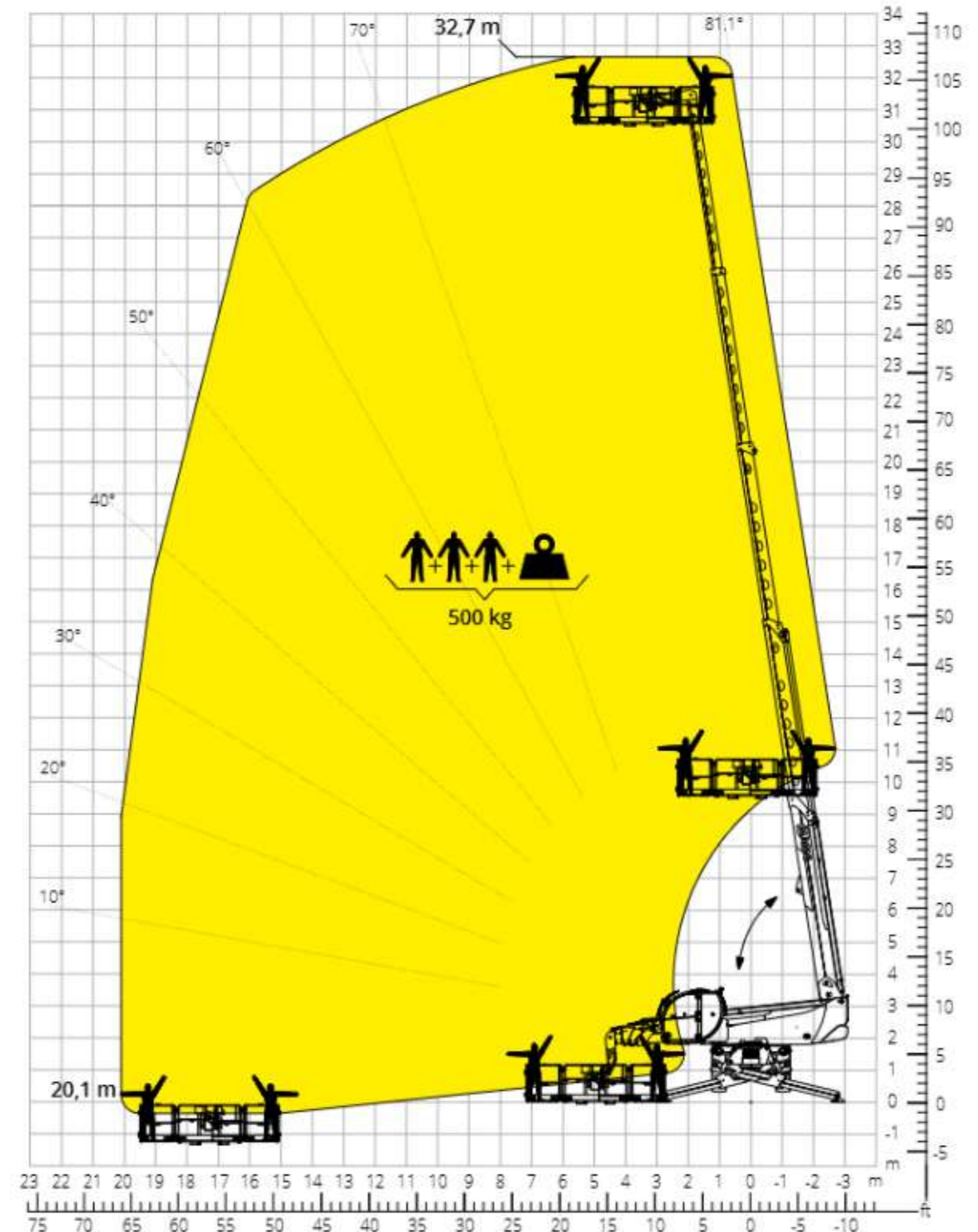

Load chart with  
**ROTATING EXTENDABLE PLATFORM, 1,000 kg**  
ATT - 01 - 016

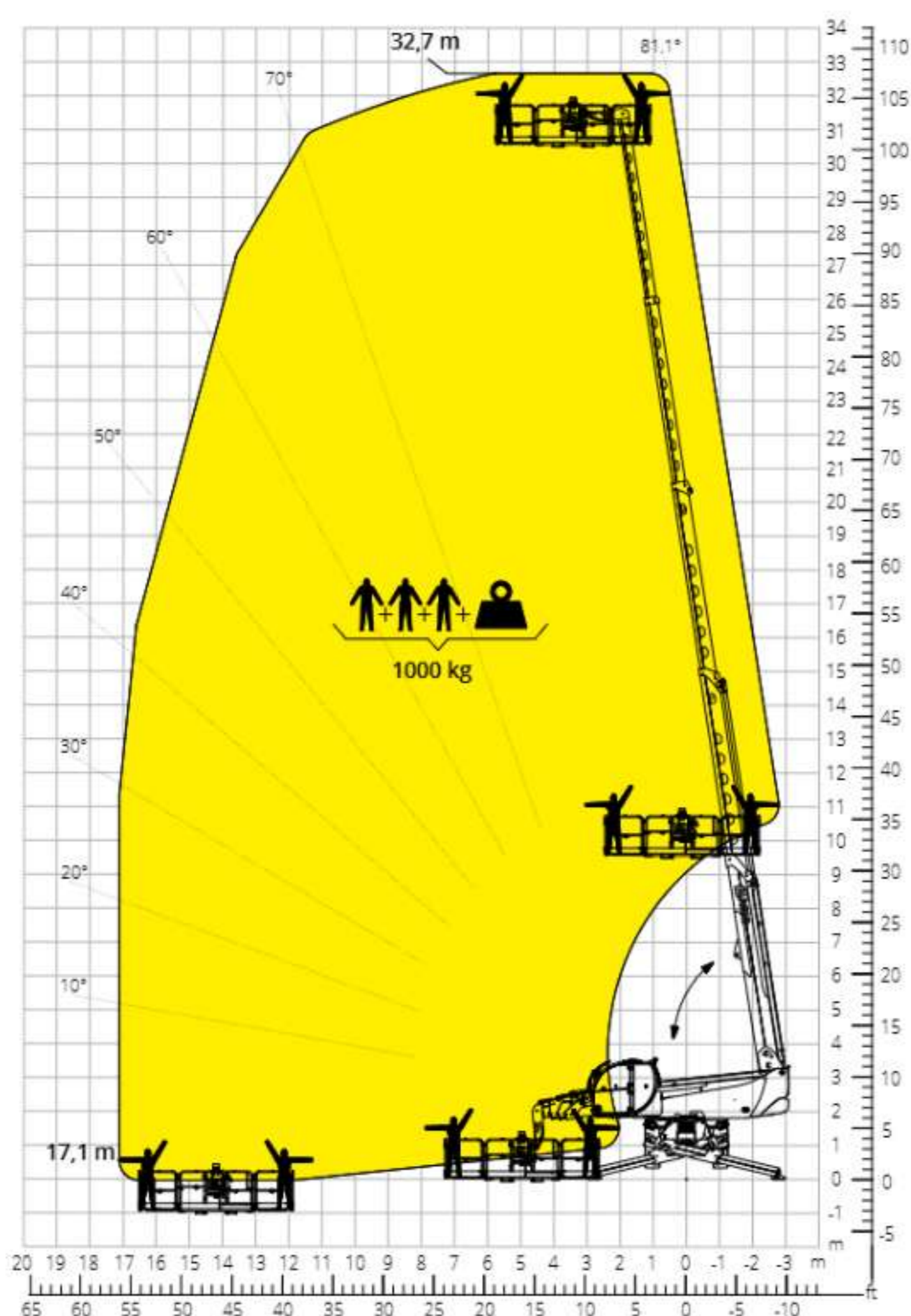

Load chart with  
**PLATFORM, 500 kg, WITH WINCH, 600 kg**  
ATT - 01 - 026

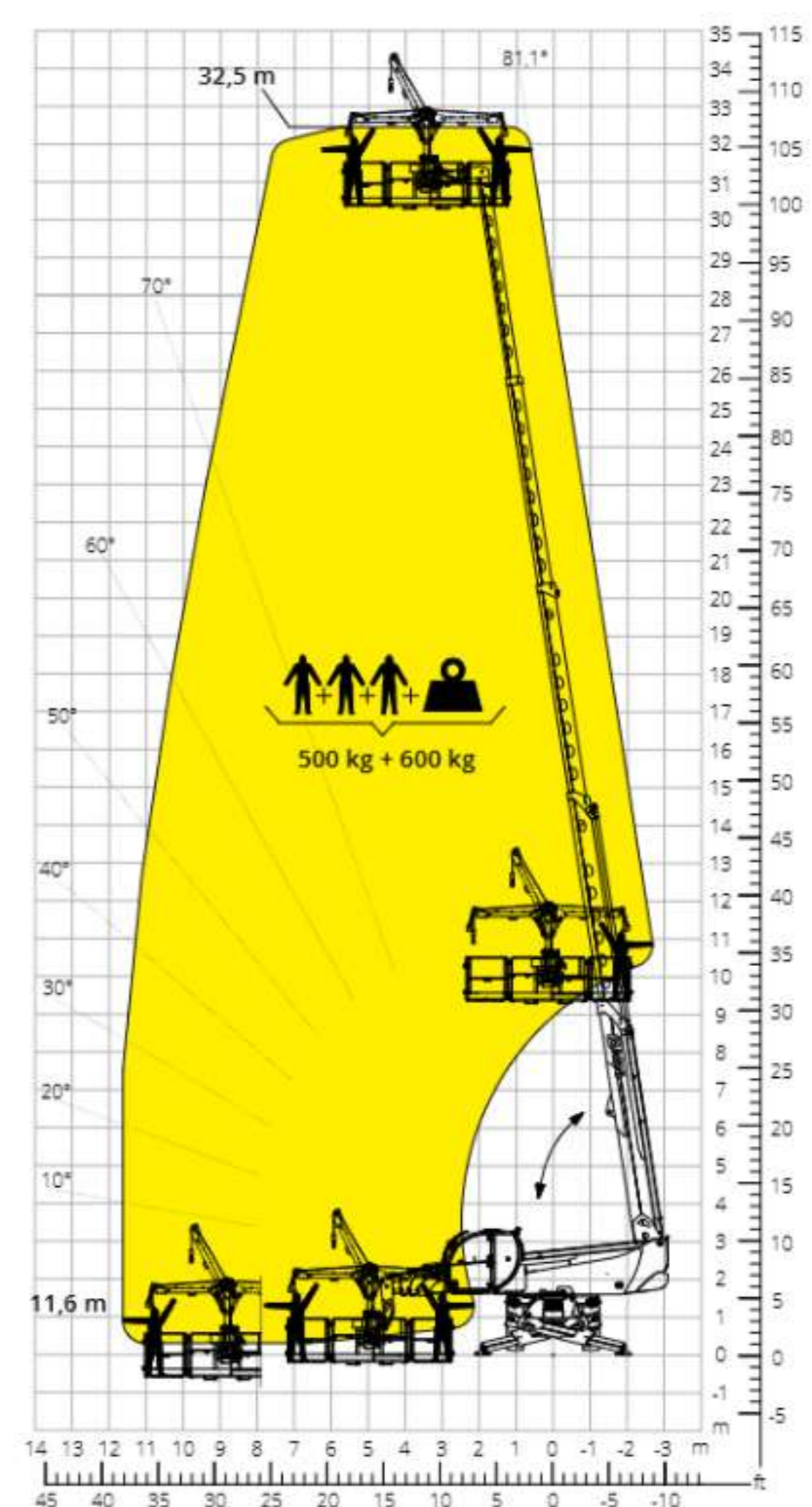

<b>Machine model</b>	Rotating telescopic handler	RTH 6.31	
	Maximum lifting capacity	6,000 kg	
	Maximum lifting height	30.80 m	
	Maximum reach	26.90 m	
	Rotation	360° (continuous)	
<b>Stabilisers</b>	Type	Telescopic scissor	
<b>Engine</b>	Model	<b>Volvo TAD 552 VE Stage IIIA</b>	<b>Volvo TAD 582 VE Stage V</b>
	Rated power	160 kW (218 hp) at 2,200 rpm	160 kW (218 hp) at 2,300 rpm
	Maximum torque	910 Nm at 1,450 rpm	925 Nm at 1,380 rpm
	Displacement	5.13 l	
	Cylinders	4 in line	
	Engine type	Turbocharged direct injection diesel	
	Cooling system	Water - intercooler	
	<b>Transmission</b>	Type	Hydrostatic
Maximum pressure		480 bar	
Gearbox		Dropbox, 2 speeds forward-reverse	
<b>Axles and brakes</b>		Type	Axles with planetary gearboxes
	Front axle	Oscillating and steering with levelling, +/-8°	
	Rear axle	Oscillating and steering with hydraulic lock	
	No. of driving/steering wheels	4WD - 4WS	
	Steering mode	Frontal/Concentric/Crab	
	Service brake	Wet multi-disk on front and rear axle	
	Parking brake	Hydraulic with negative action on front axle	
	Tyre sizes	445/65 R22.5	
<b>Performance</b>	Max. travel speed	40 km/h	
	Gradeability (unladen)	40%	
	Turning radius (at forks)	6,730 mm	
<b>Weights</b>	Total unladen*	22,700 kg	
<b>Tank and system capacities</b>	Diesel fuel	270 l	270 l
	AdBlue	-	40 l
	Hydraulic fluid	164 l	164 l
	Engine oil	16 l	16 l
	Coolant	40 l	40 l
<b>Hydraulic circuit for movements</b>	Circuit type	Load sensing	
	Service pump	Variable displacement	
	Max. hydraulic flow rate	160 l/min	
	Max. boom head flow rate	75 l/min	
	Max. working pressure	350 bar	
	Distributor for boom and turret movements	SIL 2 electro-proportional valve	
	Movements control	Dual joystick with integrated manoeuvre enable	
<b>Standards met</b>	2006/42/EC: EU Machinery Directive		
	2016/1628: EU Regulation on the emissions of stage V engines		
	EN 1459-X: Relating to standards on the safety requirements for variable reach machines		
	EN 280-1/EN 280-2: standards relating to mobile elevating work platforms (if available)		
	ROPS/level 2 FOPS: relating to the standards for protective structures		

The data given in this brochure are provided for information purposes and are subject to change without prior notice.

All images are purely guideline and might not give an exact representation of the product.

\*the stated weight refers to the vehicle unladen with standard equipment and may vary depending on the chosen configuration.

## The standard machine configuration includes:

### CAB

- “Easy access” system
- Premium tilting seat with air suspension and headrest
- Adjustable steering column
- Analogue joypad
- Adjustable sunblind
- Heating
- Air conditioning
- FM/AM radio with USB and Bluetooth connectivity
- Ambient LED lights
- USB Type-A and Type-C (5 V) inputs

### REAL TIME INFORMATION

- Touchscreen, 12”
- MCTS – Magni Combi Touch System on-board software
- Automatic RFID tools recognition system
- LMI – Load Moment Indicator
- LLD – Live Load Diagram
- Onboard and remote integrated diagnostics
- Reversing camera with image integrated in the MCTS

### TECHNICAL SPECIFICATIONS

- Q-Fit standard
- Provision for platform
- Advanced three-line CAN BUS system
- Automatic levelling system for outriggers
- Automatic front and rear wheel alignment
- High-precision turret rotation motor by Liebherr
- Automatic parking brake
- Mechanical battery cut-off in engine compartment
- Electrical system: 24 V – IP67

### SERVICE

- MyMagni by Trackunit connectivity system (Free of charge on request)
- Warranty: 24 months/2,000 hours