



Cummins Generator

Prime: 260KW/325KVA
Standby: 286KW/358KVA

Technical Data

Model		358kva
Prime power	kva	325
	kw	260
Standby power	kva	358
	kw	286
Rated voltage line to line	V	400
Rated current	A	468
Maximum sound level	dB@7m	76

Engine-Cummins

Model		6LTAA9.5-G1
Aspiration		Four-stroke, water-cooled, in-line, direct injection, turbocharged, charged air cooled
Fuel system		BYC P7100 electric governor
No. cylinders		6
Displacement	L	9,5
Bore*Stroke	mm	116x148
Compression ratio		16.6:1
Rated speed	r/min	1500
Governor		Electric system
Engine wet weight	kg	945
Engine idel speed		750-850
Fire order		1-5-3-6-2-4
Start Motor	V	24

Exhaust System

Max exhaust back pressure	kPa	10,1
---------------------------	-----	------

Air intake System

Max inlet pressure (Dirty air)	kPa	6,2
Max inlet pressure (Clean air)	kPa	3,7

Fuel System

110% load(Standby power)	L/h	78
100% load(Prime power)	L/h	70
75% load(Prime power)	L/h	52
50% load(Prime power)	L/h	35
25% load(Prime power)	L/h	18
Fuel capacity for silent genset	L	525
Fuel capacity for open genset	L	500

Lubrication System

Idle speed oil pressure	kPa	103
Governed speed oil pressure	kPa	276-414
Max Oil temp	°C	121
Oil capacity	L	28

Cooling System

Coolant capacity--Engine only	L	22
Max coolant friction head to engine	Kpa	35
Max water temp standby/prime powe	°C	110/104

Standard Features

Engine(Cummins ENGINE)	●
Radiator 50°C max,fans are driven by belt	●
24V charge alternator	●
Alternator: single bearing alternator IP23	●
insulation class H/H	●
Standard auto control system	●
One set of air filter, fuel filter, oil filter	●
Main line circuit breaker / ACB	●
Base fuel tank	●
Two 24V batteries, rac and cable	●
Exhaust system(Ripple flex exhaust pipe)	●
Exhaust siphon, flange, muffler	●
User manual	●
Battery charge	●
Water heater	●

Options

Alternator heater	<input type="radio"/>
PMG	<input type="radio"/>
Water oil separator	<input type="radio"/>
Daily fuel tank	<input type="radio"/>
Remote control panel	<input type="radio"/>
Automatic transfer switch/ATS	<input type="radio"/>
Switch box	<input type="radio"/>
Standard: ●	Options: ○

Alternator

Model		TAL-A46-G
Alternator Brand		Leroy Somer
Phase		3
Voltage	V	400
Wiring Type		12 wires
Bearing		1
Power factor		0,8
Frequency	Hz	50
Prime power	KVA	325
Exciter Type		Brushless, self-excitation
Voltage regulation	%	±0.5
Protection Grade		IP 23
Insulation grade		H

Controller-Deepsea

Model DSE6120

- 7 Configurable digital inputs
- Built-in governor and AVR control
- Base load (kW export) functionality
- Mains (utility) de-coupling protection
- Generator power (kW, kVA) monitoring
- Overload (kW & kV Ar) protection
- Emergency stop
- Start failure



Unit Dimensions(Basic unit)

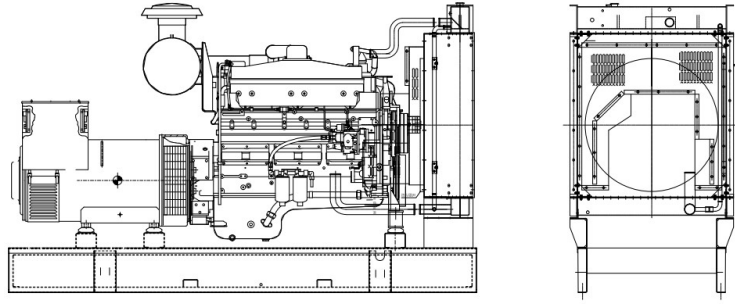

Open Type

L*W*H	mm	2900x1250x1800
Weight	kg	2610

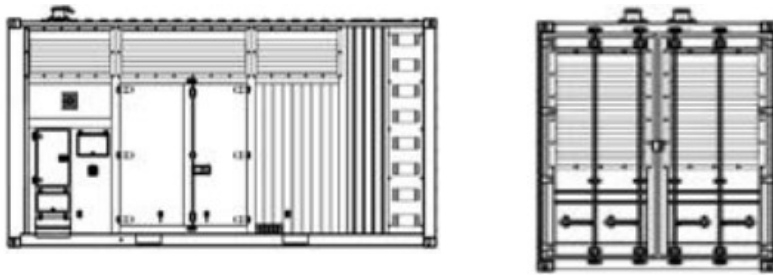

Silent Type

L*W*H	mm	3938*1300*1970
Weight	kg	3145

Warranty

Cummins Engine

12 months from date of purchase or 1000 hours.

Generator

12 months from date of purchase or 1000 hours

(whichever comes first).