

ZW-7 series

HITACHI

Reliable Solutions

ZW160



WHEEL LOADER

Model code : ZW160-7 / ZW160PL-7
Engine maximum power : 126 kW / 169 hp
124 kW (ISO9249)
Operating weight : 12 910 – 13 610 kg
Bucket capacity (heaped) : 2.0 – 3.6 m³ (ISO7546)

SPECIFICATIONS

ENGINE

| | |
|---------------------------|--|
| Model | CUMMINS B4.5 |
| Type | 4-cycle water-cooled, direct injection |
| Aspiration | Turbocharger and intercooled |
| Aftertreatment | DPF and SCR system |
| No. of cylinders | 4 |
| Maximum power | |
| ECE R120, gross | 126 kW (169 hp) at 2 000 min ⁻¹ (rpm) |
| ISO 9249: 2007, net | 124 kW (166 hp) at 2 000 min ⁻¹ (rpm) |
| Rated power | |
| ISO 14396: 2002 | 123 kW (165 hp) at 2 200 min ⁻¹ (rpm) |
| ISO 9249: 2007, net | 122 kW (163 hp) at 2 200 min ⁻¹ (rpm) |
| Maximum torque | |
| ISO 9249: 2007, net | 755 Nm at 1 200 min ⁻¹ (rpm) |
| Bore and stroke | 107 mm X 124 mm |
| Piston displacement | 4.46 L |
| Batteries | 2 x 12 V |
| Air cleaner | Two element dry type with restriction indicator |

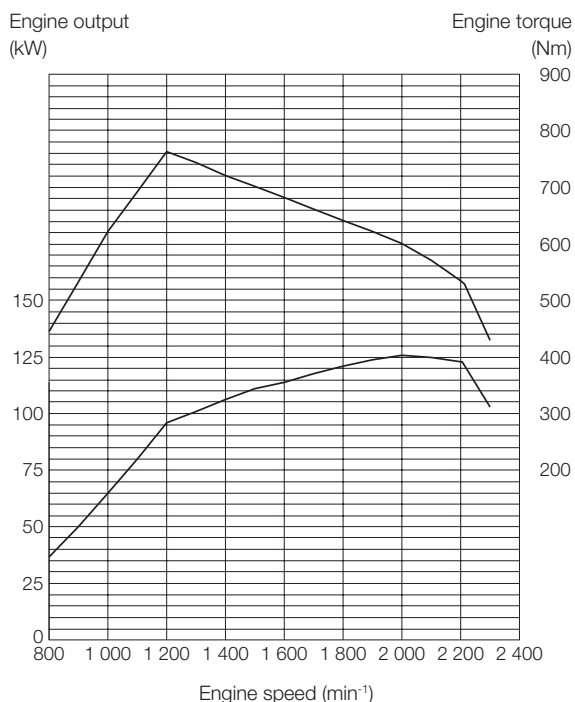

POWER TRAIN

| | |
|---------------------------------|---|
| Transmission | Electrical-controlled 2 motor hydrostatic transmission with summation gear box, Gear box : Fixed gear ratio, powershift countershaft type |
| Cooling method | Forced circulation type |
| Travel speed* Forward / Reverse | |
| 1st | 13 / 13 km/h (13 / 13 km/h) |
| 2nd | 13 / 13 km/h (13 / 13 km/h) |
| 3rd | 20 / 20 km/h (20 / 20 km/h) |
| 4th | 39 / 39 km/h (39 / 39 km/h) |
| *With 20.5 R25 (L3) tires | |
| () : Data at Power Mode | |

AXLE AND FINAL DRIVE

| | |
|---------------------------------------|---|
| Drive system | Four-wheel drive system |
| Front & rear axle | Semi-floating |
| Front | Fixed to the front frame |
| Rear | Trunnion support |
| Reduction and differential gear | Two stage reduction with torque proportional differential |
| Oscillation angle | Total 20° (+10°, -10°) |
| Final drives | Heavy-duty planetary, mounted inboard |

TIRES

| | |
|-----------------|--------------|
| Tire size | 20.5R25 (L3) |
|-----------------|--------------|

BRAKES

| | |
|----------------------|--|
| Service brakes | Inboard mounted fully hydraulic 4 wheel wet disc brakes. Front & rear independent brake circuit, HST (Hydro Static Transmission) system provides additional hydraulic braking capacity |
| Parking brakes | Spring applied, hydraulically released, wet disc type |

STEERING SYSTEM

| | |
|---------------------------|--------------------------------|
| Type | Articulated frame steering |
| Steering angle | Each direction 40° ; total 80° |
| Cylinders | Double-acting piston type |
| No. x Bore x Stroke | 2 x 65 mm x 419 mm |

HYDRAULIC SYSTEM

| | |
|---|---|
| Arm and bucket are controlled by multifunction lever | |
| Arm controls | Four position valve; raise, hold, lower, float |
| Bucket controls with automatic bucket return-to-dig control | Three position valve; roll back, hold, dump |
| Main pump (Serve as steering pump) | |
| Gear type | |
| Maximum flow | 194 L/min at 2 200 min ⁻¹ (rpm) |
| Maximum pressure ... | 20.6 MPa |
| Brake & fan & pilot oil pump | |
| Gear type | |
| Maximum flow | 44.9 L/min at 2 200 min ⁻¹ (rpm) |
| Maximum pressure ... | 15.5 MPa |
| ZW160-7 Hydraulic cylinders | |
| Type | Double acting type |
| No. x Bore x Stroke ... | Arm : 2 x 125 mm x 760 mm Bucket : 1 x 150 mm x 495 mm |
| Filters | Full-flow 10 micron return filter in reservoir |
| ZW160PL-7 Hydraulic cylinders | |
| Type | Double acting type |
| No. x Bore x Stroke ... | Arm : 2 x 125 mm x 760 mm Bucket : 2 x 110 mm x 1 005 mm |
| Filters | Full-flow 10 micron return filter in reservoir |
| Hydraulic cycle times | |
| Lift arm raise | ZW160-7 : 6.4 s ZW160PL-7 : 6.8 s |
| Lift arm lower | ZW160-7 : 3.8 s ZW160PL-7 : 3.6 s |
| Bucket dump | ZW160-7 : 1.6 s ZW160PL-7 : 3.4 s |
| Total | ZW160-7 : 11.8 s ZW160PL-7 : 13.8 s |

*Data at Power Mode

ENVIROMENT

Engine Emissions

Complies with EU stage V

Sound level

External sound level according To ISO 6395: 2008

and EU Directive 2000/14/EC 104 LwA dB(A)

Sound level in cabin according to ISO 6396: 2008..... 67 LpA dB(A)

Air Conditioning System

The air conditioning system contains fluorinated greenhouse gases.

Refrigerant type: HFC-134a, GWP: 1430, Amount: 0.75±0.05kg,

CO₂e: 1.07±0.07ton.

SERVICE REFILL CAPACITIES

| | |
|--|-------|
| Fuel tank | 205 L |
| Engine coolant | 20 L |
| Engine oil (Including oil pan) | 16 L |
| Front axle differential & wheel hubs | 27 L |
| Rear axle differential & wheel hubs | 27 L |
| Hydraulic oil tank | 80 L |
| DEF/AdBlue tank | 25 L |

DIMENSIONS & SPECIFICATIONS ZW160-7

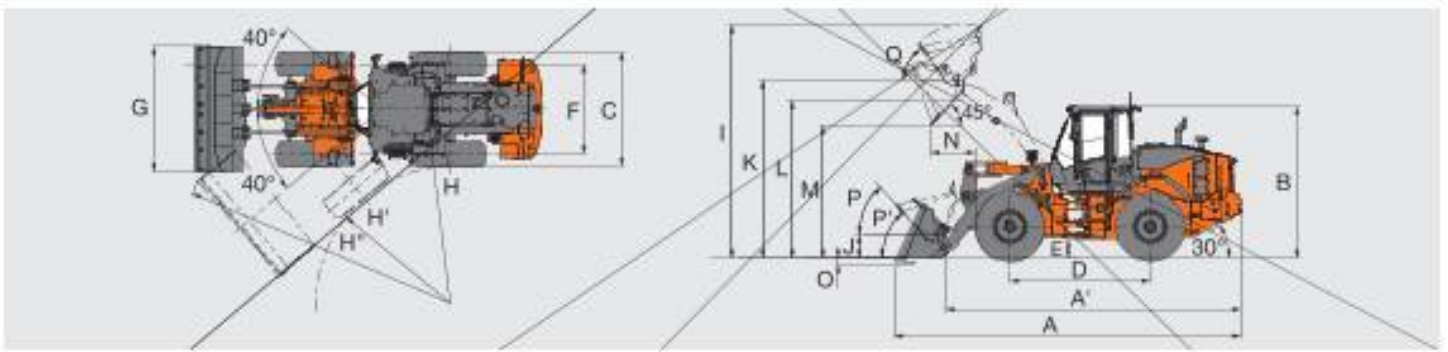

| Bucket type | | | Standard arm | | | | | High-lift arm | | | |
|---|-----------------------|----------------|-----------------|----------------------|---------------|----------------------|----------------------|---------------|----------------------|---------------|----------------------|
| | | | General purpose | | | | | | | | |
| | | | Weld-on teeth | Bolt-on cutting edge | Weld-on teeth | Bolt-on cutting edge | Bolt-on cutting edge | Weld-on teeth | Bolt-on cutting edge | Weld-on teeth | Bolt-on cutting edge |
| Bucket capacity | ISO 7546: 1983 Heaped | m ³ | 2.2 | 2.2 | 2.4 | 2.4 | 3.6 | 2.0 | 2.0 | 2.2 | 2.2 |
| | ISO 7546: 1983 Struck | m ³ | 1.8 | 1.8 | 2.0 | 2.0 | 3.1 | 1.6 | 1.6 | 1.8 | 1.8 |
| A Overall length | | mm | 7 670 | 7 515 | 7 720 | 7 565 | 7 810 | 8 110 | 7 955 | 8 160 | 8 005 |
| A' Overall length (Without Bucket) | | mm | 6 420 | 6 420 | 6 420 | 6 420 | 6 420 | 6 905 | 6 905 | 6 905 | 6 905 |
| B Overall height | up to cab top | mm | 3 280 | 3 280 | 3 280 | 3 280 | 3 280 | 3 280 | 3 280 | 3 280 | 3 280 |
| C Width over tires | outside tire | mm | 2 500 | 2 500 | 2 500 | 2 500 | 2 500 | 2 500 | 2 500 | 2 500 | 2 500 |
| D Wheel base | | mm | 3 000 | 3 000 | 3 000 | 3 000 | 3 000 | 3 000 | 3 000 | 3 000 | 3 000 |
| E Ground clearance | Minimum | mm | 430 | 430 | 430 | 430 | 430 | 430 | 430 | 430 | 430 |
| F Tread | | mm | 1 930 | 1 930 | 1 930 | 1 930 | 1 930 | 1 930 | 1 930 | 1 930 | 1 930 |
| G Bucket width | | mm | 2 535 | 2 535 | 2 535 | 2 535 | 2 700 | 2 535 | 2 535 | 2 535 | 2 535 |
| H Turning radius (Centerline of outside tire) | | mm | 5 085 | 5 085 | 5 085 | 5 085 | 5 085 | 5 085 | 5 085 | 5 085 | 5 085 |
| H' Turning radius to inside of tires | | mm | 2 870 | 2 870 | 2 870 | 2 870 | 2 870 | 2 870 | 2 870 | 2 870 | 2 870 |
| H'' Loader clearance radius, bucket in carry position | | mm | 5 980 | 5 940 | 5 995 | 5 955 | 6 100 | 6 180 | 6 130 | 6 195 | 6 150 |
| I Overall operating height | bucket full raise | mm | 5 040 | 5 040 | 5 110 | 5 110 | 5 455 | 5 350 | 5 350 | 5 415 | 5 415 |
| J Carry height of bucket pin | at carry position | mm | 385 | 385 | 385 | 385 | 385 | 385 | 385 | 385 | 385 |
| K Height to bucket hinge pin, fully raised | | mm | 3 840 | 3 840 | 3 840 | 3 840 | 3 840 | 4 210 | 4 210 | 4 210 | 4 210 |
| L Lift arm clearance at max. lift | | mm | 3 570 | 3 550 | 3 570 | 3 550 | 3 550 | 3 940 | 3 920 | 3 940 | 3 920 |
| M Dumping clearance 45 deg, full height | | mm | 2 690 | 2 795 | 2 655 | 2 760 | 2 590 | 3 095 | 3 200 | 3 060 | 3 165 |
| N Reach 45 deg dump, full height | | mm | 1 145 | 1 010 | 1 185 | 1 045 | 1 215 | 1 300 | 1 160 | 1 335 | 1 200 |
| O Digging depth (Horizontal digging angle) | | mm | 80 | 105 | 80 | 105 | 105 | 205 | 225 | 205 | 225 |
| P Max. roll back at carry position | | deg | 46 | 46 | 46 | 46 | 46 | 47 | 47 | 47 | 47 |
| P' Max. roll back at ground level | | deg | 43 | 43 | 43 | 43 | 43 | 44 | 45 | 44 | 45 |
| Q Roll back angle at full height | | deg | 59 | 59 | 59 | 59 | 59 | 54 | 54 | 54 | 54 |
| Static tipping load ISO 14397-1: 2007(Section 1-5) * | Straight | kg | 10 610 | 10 480 | 10 530 | 10 450 | 10 410 | 8 490 | 8 390 | 8 450 | 8 340 |
| | Full turn | kg | 9 210 | 9 090 | 9 140 | 9 050 | 9 020 | 7 330 | 7 240 | 7 300 | 7 190 |
| Breakout force | | kN | 105 | 99 | 99 | 94 | 77 | 103 | 97 | 98 | 92 |
| | | kgf | 10 690 | 10 080 | 10 120 | 9 570 | 7 800 | 10 490 | 9 880 | 9 950 | 9 390 |
| Operating weight * (With ROPS / FOPS Cab) | | kg | 12 910 | 12 980 | 13 020 | 13 090 | 13 060 | 13 080 | 13 150 | 13 120 | 13 190 |

Note: All dimensions, weight and performance data based on ISO 6746-1 : 1987, ISO 7137 : 2009 and ISO 7546 : 1983

: Static tipping load and operating weight marked with include 20.5R25 (L3) tires (No ballast) with lubricants, full fuel tank and operator.

Machine stability and operating weight depend on counterweight, tire size and other attachments.

WEIGHT CHANGE

| Option item | Operating weight (kg) | Tipping load (kg) | | Overall width (mm) (outside tire) | Overall height (mm) | Overall length (mm) |
|-------------|---------------------------|-------------------|-----------|-----------------------------------|---------------------|---------------------|
| | | Straight | Full turn | | | |
| Tire | 20.5R25 (L3) XHA2 | ±0 | ±0 | ±0 | ±0 | ±0 |
| | 20.5R25 (L5) XLD D2A | +460 | +340 | +300 | +15 | +30 |
| | 20.5R25 (L5) XMINE D2 PRO | +620 | +460 | +400 | +10 | +35 |
| | 20.5R25 (L2) XSNOPPLUS | ±70 | ±50 | ±50 | +5 | -10 |
| | 20.5R25 (L3) VJTZ | +10 | +10 | +10 | ±0 | -5 |
| | 20.5R25 (L3) TL-3A+ | +150 | +110 | +100 | +15 | -5 |
| Belly guard | +70 | +40 | +40 | ±0 | ±0 | ±0 |

BUCKET SELECTION GUIDE

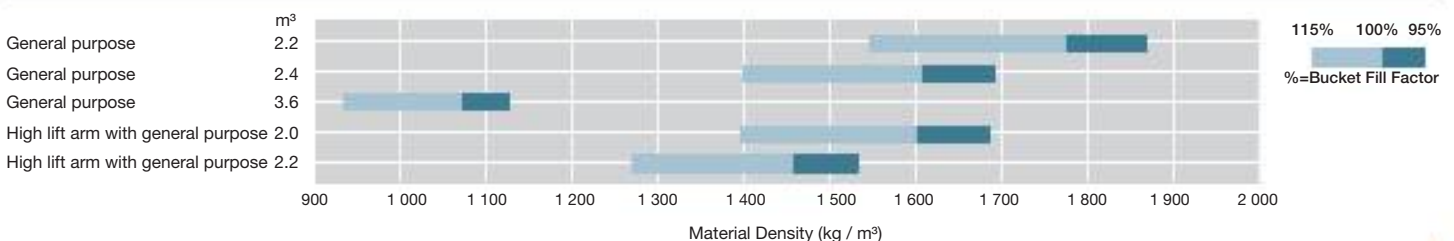

SPECIFICATIONS

DIMENSIONS & SPECIFICATIONS ZW160PL-7

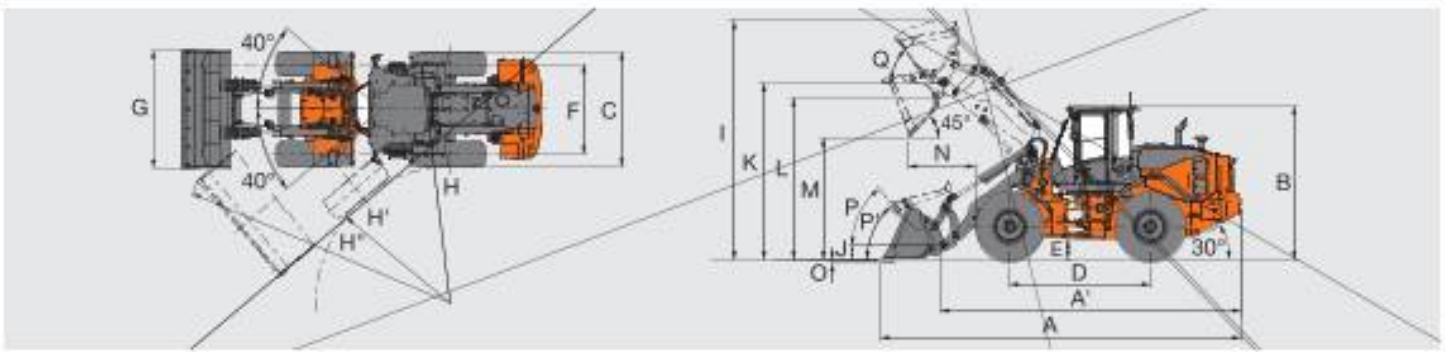

| Bucket type | | General purpose | | | | |
|--|-----------------------|-----------------|--------|----------------------|--------|--------|
| | | Weld-on teeth | | Bolt-on cutting edge | | |
| Bucket capacity | ISO 7546: 1983 Heaped | m³ | 2.1 | 2.1 | 2.2 | 2.2 |
| | ISO 7546: 1983 Struck | m³ | 1.8 | 1.8 | 1.9 | 1.9 |
| A Overall length | | mm | 7 915 | 7 765 | 7 920 | 7 760 |
| A' Overall length (Without Bucket) | | mm | 6 565 | 6 565 | 6 565 | 6 565 |
| B Overall height | up to cab top | mm | 3 280 | 3 280 | 3 280 | 3 280 |
| C Width over tires | outside tire | mm | 2 500 | 2 500 | 2 500 | 2 500 |
| D Wheel base | | mm | 3 000 | 3 000 | 3 000 | 3 000 |
| E Ground clearance | Minimum | mm | 430 | 430 | 430 | 430 |
| F Tread | | mm | 1 930 | 1 930 | 1 930 | 1 930 |
| G Bucket width | | mm | 2 535 | 2 535 | 2 535 | 2 535 |
| H Turning radius (Centerline of outside tire) | | mm | 5 085 | 5 085 | 5 085 | 5 085 |
| H' Turning radius to inside of tires | | mm | 2 870 | 2 870 | 2 870 | 2 870 |
| H" Loader clearance radius, bucket in carry position | | mm | 6 055 | 6 010 | 6 055 | 6 010 |
| I Overall operating height | bucket full raise | mm | 5 280 | 5 280 | 5 320 | 5 320 |
| J Carry height of bucket pin | at carry position | mm | 390 | 390 | 390 | 390 |
| K Height to bucket hinge pin, fully raised | | mm | 3 975 | 3 975 | 3 975 | 3 975 |
| L Lift arm clearance at max. lift | | mm | 3 690 | 3 665 | 3 690 | 3 665 |
| M Dumping clearance 45 deg, full height | | mm | 2 650 | 2 755 | 2 645 | 2 760 |
| N Reach 45 deg dump, full height | | mm | 1 415 | 1 280 | 1 420 | 1 275 |
| O Digging depth (Horizontal digging angle) | | mm | 105 | 125 | 105 | 125 |
| P Max. roll back at carry position | | deg | 47 | 47 | 47 | 47 |
| P' Max. roll back at ground level | | deg | 44 | 45 | 44 | 45 |
| Q Roll back angle at full height | | deg | 53 | 53 | 53 | 53 |
| Bucket weight | | kg | 950 | 1 020 | 950 | 1 010 |
| Static tipping load ISO 14397-1: 2007(Section 1-5) * | Straight | kg | 9 680 | 9 570 | 9 770 | 9 680 |
| | Full turn | kg | 8 360 | 8 250 | 8 440 | 8 350 |
| Breakout force | | kN | 105 | 100 | 104 | 101 |
| | | kgf | 10 670 | 10 210 | 10 620 | 10 250 |
| Operating weight * (With ROPS / FOPS Cab) | | kg | 13 540 | 13 610 | 13 530 | 13 600 |

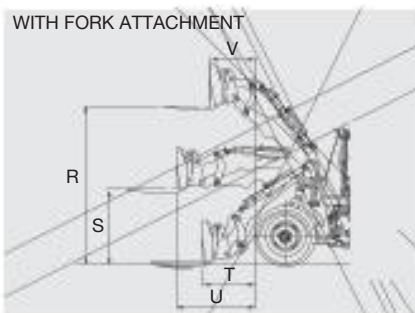

| Attachment type | | Fork | |
|---------------------------------|---------------------------------|------|--------|
| R | Max. stacking height | mm | 3 750 |
| S | Height of fork at maximum reach | mm | 1 820 |
| T | Reach at ground level | mm | 1 245 |
| U | Max. reach | mm | 1 875 |
| V | Reach at max. stacking height | mm | 1 080 |
| Static tipping load | Straight | kgf | 6 830 |
| | Full 40 degree turn | kgf | 5 920 |
| Max. payload per EN 474-3, 80 % | | kg | 4 740 |
| Max. payload per EN 474-3, 60 % | | kg | 3 550 |
| Fork tine length | | mm | 1 220 |
| Operating weight * | | kg | 13 110 |

Note: *: Static tipping load and operating weight marked with* include 20.5R25 (L3) tires (No ballast) with lubricants, full fuel tank and operator. Machine stability and operating weight depend on counterweight, tire size and other attachments.

WEIGHT CHANGE

| Option item | Operating weight (kg) | Tipping load (kg) | | Overall width (mm) (outside tire) | Overall height (mm) | Overall length (mm) |
|-------------|---------------------------|-------------------|-----------|-----------------------------------|---------------------|---------------------|
| | | Straight | Full turn | | | |
| Tire | 20.5R25 (L3) XHA2 | ±0 | ±0 | ±0 | ±0 | ±0 |
| | 20.5R25 (L5) XLD D2A | +460 | +290 | +260 | +15 | +30 |
| | 20.5R25 (L5) XMINE D2 PRO | +620 | +390 | +350 | +10 | +35 |
| | 20.5R25 (L2) XSNOPLUS | ±70 | +40 | +40 | +5 | -10 |
| | 20.5R25 (L3) VJTZ | +10 | +10 | +10 | ±0 | -5 |
| | 20.5R25 (L3) TL-3A+ | +150 | +100 | +80 | +15 | -5 |
| Belly guard | +70 | +40 | +30 | ±0 | ±0 | ±0 |

EQUIPMENT

● : Standard equipment ○ : Optional equipment — : Not applicable

| ENGINE | ZW160-7 | ZW160PL-7 |
|--|---------|-----------|
| Aftertreatment device | ● | ● |
| Aftertreatment manual regeneration inhibit switch | ● | ● |
| Aftertreatment manual regeneration switch | ● | ● |
| Air filter double elements | ● | ● |
| Air intake | | |
| Pre-cleaner (Sy-Klone type) | ● | ● |
| Pre-cleaner (Turbo II) | ○ | ○ |
| Anti-clogging radiator (Wide fin pitch) | ● | ● |
| Automatic reversible cooling fan with heat sensing | ● | ● |
| Cartridge-type engine oil filter | ● | ● |
| Cartridge-type fuel main filter | ● | ● |
| Cartridge-type fuel pre-filter (with water separator function) | ● | ● |
| Coolant reservoir sight gauge | ● | ● |
| DEF/AdBlue® tank with magnet adapter | ● | ● |
| Engine auto shut-down control system | ● | ● |
| Engine oil remote drain | ● | ● |
| Fan guard | ● | ● |

| BRAKE SYSTEM | | |
|--|---|---|
| Front & rear independent brake circuit | ● | ● |
| Inboard mounted fully hydraulic 4 wheel wet disc | ● | ● |
| Spring applied/Hydraulic-released parking brake | ● | ● |

| HYDRAULIC SYSTEM | | |
|---|---|---|
| Bucket auto leveler (Automatic return to dig control) | ● | ● |
| Control lever lock switch | ● | ● |
| Dual lift arm auto leveler and kickout system | ● | ● |
| Electric Control lever | | |
| for 3 spools control valve | | |
| MF lever & Proportional switch for 3rd function | ● | ● |
| for 4 spools control valve | | |
| MF lever & 2 Proportional switch for 3rd & 4th function | ○ | — |
| Hydraulic filters | ● | ● |
| Lift arm float system | ● | ● |
| Quick coupler piping and switch | ○ | ● |
| Reservoir sight gauge | ● | ● |
| Ride control system (OFF-AUTO type) | ● | ● |
| Work mode selector | ● | ● |

| CAB | ZW160-7 | ZW160PL-7 |
|---|---------|-----------|
| Adjustable steering column with POP-UP | ● | ● |
| Auto control air conditioner | | |
| With double intake filters | ● | ● |
| Pre-cleaner for air conditioner | ○ | ○ |
| Bluetooth® integrated DAB+radio, hands-free calling | ● | ● |
| Camera & monitor | | |
| Rear view camera & monitor | ● | ● |
| AERIAL ANGLE (Side and rear view camera) | ○ | ○ |
| Coat hook | ● | ● |
| Evacuation hammer | ● | ● |
| Front/Rear defroster | ● | ● |
| Glove compartment | ● | ● |
| LED room light | ● | ● |
| Payload checker with tip-off function | ● | — |
| Rear obstacle detection system | ○ | ○ |
| Rear obstacle detection system (Automatic speed reduction) | ○ | ○ |
| Rear view mirrors | | |
| Inside (1) | ● | ● |
| Outside (Heated, 2) electrical adjustment with proximity | ● | ● |
| Retractable seat belt, 50 mm | ● | ● |
| ROPS (ISO 3471:2008), FOPS (ISO 3449:2008 LEVEL II): multi-plane isolation mounted for noise, vibration reduction | ● | ● |
| Rubber floor mat | ● | ● |
| Seat | | |
| Heavy Duty air suspension seat equipped with horizontal suspension, headrest and heater: fabric, high back, adjustable for damper, inclination of the seat, seat depth, weight-height, fore-aft position, reclining angle, armrest angle, headrest height and angle, lumbar support | ● | ● |
| Seat belt reminder | ● | ● |
| Steering system | | |
| Wheel steering | ● | ● |
| Storage | | |
| Cup holder | ● | ● |
| Document holder | ● | ● |
| Hot & cool box | ● | ● |
| Seatback pocket | ● | ● |
| Smartphone and Tablet device holder | ● | ● |
| Sun shade film on front windshield | ○ | ○ |
| Sunscreen roller type | ● | ● |
| Textured steering wheel with spinner knob | ● | ● |
| Tinted safety glass | | |
| Front windshield: laminated | ● | ● |
| Others: tempered | ● | ● |
| USB power supply | ● | ● |
| Windshield washer front and rear | ● | ● |
| Windshield wipers front and rear | ● | ● |
| 2 speakers | ● | ● |
| 8 inch sub monitor | ● | ● |

● : Standard equipment ○ : Optional equipment — : Not applicable

| MONITORING SYSTEM | ZW160-7 | ZW160PL-7 |
|---|---------|-----------|
| Gauge: coolant temperature, fuel level, transmission oil temperature | ● | ● |
| Indicator lights : clearance lights, control lever lock, fuel level, high beam, parking brake, preheat, turn signals, work lights, fan reverse indicator, seat belt indicator | ● | ● |
| Indicator on multifunction monitor: F-N-R shift position, gear shift position, clock, DEF alarm indicator, DEF level gauge, ECO indicator, forward/reverse selector switch indicator, hold display, hour meter, odometer, battery volt, speedometer, tachometer, transmission auto-shifting indicator, Warning lights: air filter restriction, brake oil low pressure, communication system error, discharge warning, engine oil low pressure, engine warning, hydraulic oil level, low steering oil pressure, overheat, transmission warning | ● | ● |
| Indicator on sub monitor : payload checker (excluding PL), dual auto-leveler indicator rear obstacle detection and warning system (optional) | ● | ● |
| 38 languages selection | ● | ● |

| ELECTRICAL SYSTEM | ZW160-7 | ZW160PL-7 |
|----------------------------|---------|-----------|
| Alternator (95A) | ● | ● |
| Backup alarm | ● | ● |
| Battery disconnect switch | ● | ● |
| Large capacity batteries | ● | ● |
| Power outlet 12 V and 24 V | ● | ● |

| LIGHTS | ZW160-7 | ZW160PL-7 |
|--|---------|-----------|
| Clearance lights | ● | ● |
| LED brake & tail lights | ● | ● |
| LED headlights | ● | ● |
| Rotating lamp | ○ | ○ |
| Turn signals with hazard switch | ● | ● |
| Work lights | | |
| 2 front on cab & 2 rear LED working lights | ● | ● |
| 2 front on cab & 2 rear LED working lights (High brightness) | ○ | ○ |
| 4 front, 2 rear on cab & 2 rear LED working lights | ○ | ○ |
| 4 front, 2 rear on cab & 2 rear LED working lights (High brightness) | ○ | ○ |

| POWER TRAIN | ZW160-7 | ZW160PL-7 |
|---|---------|-----------|
| Approach speed control | ● | ● |
| Deceleration select switch | ● | ● |
| Differential | | |
| LSD (Limited Slip Differential, front and rear) | ○ | ○ |
| TPD (Torque Proportioning Differential, front and rear) | ● | ● |
| Driving speed limiter (20km/h) | ○ | ○ |
| Electrically controlled HST system | ● | ● |
| Forward/Reverse lever | ● | ● |
| Forward/Reverse selector switch | ● | ● |
| Power mode switch | ● | ● |
| Traction control switch | ● | ● |
| 1st speed limited switch | ● | ● |

| TIRES | ZW160-7 | ZW160PL-7 |
|--------------------------|---------|-----------|
| 20.5R25 (L2) XSNOPLUS | ○ | ○ |
| 20.5R25 (L3) TL-3A+ | ○ | ○ |
| 20.5R25 (L3) VJT | ○ | ○ |
| 20.5R25 (L3) XHA2 | ● | ● |
| 20.5R25 (L5) XLDD2A | ○ | ○ |
| 20.5R25 (L5) XMINED2 PRO | ○ | ○ |

| MISCELLANEOUS | ZW160-7 | ZW160PL-7 |
|--|---------|-----------|
| Articulation lock bar | ● | ● |
| Belly guard (Bolt on type) (front / rear) | ○ | ○ |
| Bucket cylinder guard | ○ | ○ |
| Cab top rail | | |
| Front rail on the cab top | ● | ● |
| Rear rail on the cab top | ● | ● |
| Counterweight, built-in | ● | ● |
| Cutting edge protection | ○ | ○ |
| Drawbar with locking pin | ● | ● |
| Emergency steering | ● | ● |
| Fenders | | |
| for 20.5 R25 (Front & full covered rear fenders with mud flaps) | ● | ● |
| Global e-Service | ● | ● |
| Lift & tie down hooks | ● | ● |
| Lift arm | | |
| Standard lift arm | ● | — |
| High lift arm | ○ | — |
| Parallel lift arm | — | ● |
| On board information controller | ● | ● |
| Pilfer proof | | |
| Battery cover with locking bracket | ● | ● |
| Lockable engine cover | ● | ● |
| Lockable fuel refilling cap | ● | ● |
| Quick coupler | — | ● |
| Radiator dust protection screen | ○ | ○ |
| Rear licence plate bracket | ○ | ○ |
| Road homologation | | |
| German road homologation kit: rear license plate bracket, reflective sticker, wheel blocks | ○ | ○ |
| Italian road homologation kit: cab lights, bucket cutting edge protection, link stopper, rear license plate bracket, reflective sticker, rotating lamp | ○ | ○ |
| Spanish road homologation kit: rear license plate bracket, rotating lamp | ○ | ○ |
| Standard tool kit | ● | ● |
| Wheel blocks | ○ | ○ |