



Mini Dumper H100



Thanks to compact dimensions and excellent control, Heracels Wheel Dumpers cannot only work in many grounds, but also tackle different problems. The hydraulic drive system makes operation more comfortable and easier. Operators can learn how to use the machines much more quickly. The individual wheel motor gives an excellent ground clearance that can make machines to be operated in restricted areas. Reliability, durability and low maintenance makes wheel dumpers a good investment.

1. The Compact dimension is available for agriculture, industry and construction and so on. It is also able to deal with a lot of issues.
2. The engine performance of the hydraulic drive system is very high.
3. The designation of machines guarantee the service life and eliminate wear and tear.
4. Different operations concentrate on one handler, so it is easy to operate for you.

Technical specifications

Operating data

Payload kg	1000kg
Shipping weight kg	1000kg
Skip capacity level	650
Skip capacity heaped	800
Tires	10.0/75-15.3
Tire width mm	264
L x W x H mm	3320×1150×2150
Bucket Capacity:	0.6m ³
Maximum Transport Weight:	1T
Cross Weight:	1.68T

Engine / Motor

Make	Yanmar
Model	3TNV88F-ESSY
Capacity	litter 1.642
Aspiration	Natural
Engine Performance	17.4KW
Engine RPM	2200rpm
Gross torque rating	82.6~91.4
Discharge	Tier4



Specification

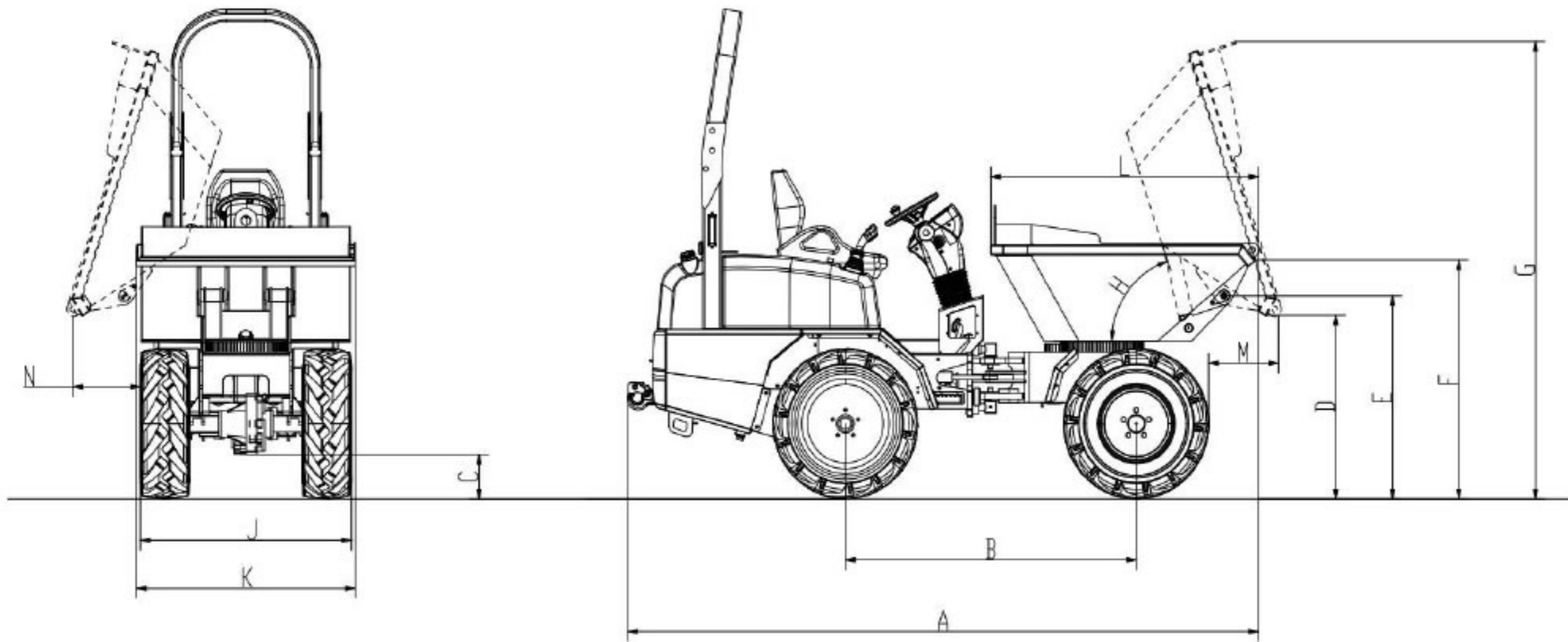

A	Overall Length:mm	3320
B	Wheel Base:mm	1530
C	Minimum Ground Clearance: mm	227
D	Dump Height: mm	935
E	Shaft Height: mm	1033
F	Front Edge Height of the Bucket: mm	1217
G	Maximum Dump Height: mm	2327
H	Dump Angle	72°
I	Overall Height : mm	2400
J	Overall Wheel Width: mm	1160
K	Skip Width:mm	1150
L	Tipping Bucket Length: mm	1410
M	Safe Dumping Distance Front: mm	367
N	Safe Dumping Distance Lateral: mm	335

	Hydraulic Tank Capacity: L	30
	Diesel Tank Capacity : L	30
	Maximum Travel Speed: KM/h	14
	Gradeability:	30%
	Max Turning Angle of the Bucket	±90°

Please note: that product availability can vary from country to country. It is possible that information / products may not be available in your country. More detailed information on engine power can be found in the operator's manual; the stated power may vary due to specific operating conditions. Subject to alterations and errors excepted. Applicable also to illustrations.

Copyright © 2019 HERACLES SE.