



## ***SIMBA S7***

The Simba S7 is Atlas Copco's rugged rig for tight, tough conditions. Smart design and increased automation give you flexibility, versatility and reliability.



***Atlas Copco***

# SIMBA S7

## FLEXIBILITY, VERSATILITY AND RELIABILITY

MAXIMIZE PRODUCTIVITY IN SMALL SPACES WITH THE SIMBA S7. THIS HYDRAULIC LONG-HOLE DRILL RIG IS BUILT FOR SMALL SPACES AND TOUGH DRILLING CONDITIONS. INCREASED AUTOMATION LETS YOU ADD THE FUNCTIONALITY YOU NEED TO THIS VERSATILE RIG.

### + RCS FOR MORE ACCURATE DRILLING

**Flexibility** Simba S7 is a compact long-hole production drill rig – highly maneuverable in small to medium drift sizes. Simba’s well-proven control system add-on increases automated functionality. Choose what level of automation you need to optimize your planning, monitoring and performance.

**Versatility** Modular automation solutions mean you can do more with your Simba S7. The control system includes ABC Regular, our One Hole Automation System. The Extractor option gives the operator more control of the drilling process in broken rock conditions. Drill Plan Handling and Void Detection options add even more value to your investment.

**Reliability** Made for hard rock drilling, the COP1838+ and MUX+ are Atlas Copco’s hydraulic top hammers, designed to excel in tough working conditions.

Front and rear mounted stingers for stable set up for drilling

Sturdy hydraulic boom concept enables stable set up of the drilling unit

Made for hard rock drilling, the COP1838+ and MUX+ are Atlas Copco’s hydraulic top hammers, designed to excel in tough working conditions



ROPS and FOPS approved Cabin for a safe and comfortable operator environment



# INCREASED PRODUCTIVITY IMPROVES PROFIT

THE SIMBA S-SERIES WAS DESIGNED WITH THE BOTTOM LINE IN MIND. THE RESULT IS RUGGED PERFORMANCE, FLEXIBLE AUTOMATION AND IMPROVED SAFETY ALL IN ONE PACKAGE.



## + SAFETY LEADS TO SUCCESS

Safer working conditions add value to your operations in the form of happier, healthier personnel and decreased stoppages. Safety precautions like automatic drill stoppage prevent accidents involving both personnel and equipment. Add-on automation, including tele remote control, greatly improve the operator's work environment.



## + AUTOMATION READY

The automation ready Simba S7 gives you the power to continually upgrade your machinery with the functions you need. Enhance the overall productivity of your operations by allowing drilling through shift changes and breaks.



## + CUSTOMER BASED SOLUTIONS

Atlas Copco strives to be the industry leader in automation technology and competency. Over the last 20 years, we have refined our solutions via practical work experience and an on-going dialogue with partners and clients. Today, more than 3 000 RCS-equipped rigs are adding value and precision to mining operations around the world.

## – IT'S NOT JUST ABOUT OUR PROMISES, IT'S ABOUT DELIVERY

We offer several levels of service agreements to meet the requirements of your operation and to secure your productivity. Our service agreements help you build a quality operation focused on proactive, planned maintenance to minimize unplanned downtime. We support maintenance with detailed parts information on every piece within our full inventory of components, accessories, and tools.



**DRILLING SYSTEM**

COP 1838+	○
COP 1838MUX+	○
Dry drilling system	○
Thread lubrication kit	○
Hole blowing kit (internal system with CE certified air reciever) Note: Not valid when using DCT.	●
Water mist flushing, external water and air supply (Hydraulic oil cooled by water cooler)	○
Water mist flushing, external water and air supply (Hydraulic oil cooled by air fan)	○
Rock drill lubrication warning kit	●
Drill stop*	○

\*Mandatory for CE

**BOOM/DRILLING UNIT**

BUT 32PD	●
Rod Handling System, RHS 10 (10+1 rods) Mechanized drilling up to 20 m*	●
Adaptable to 4', 5' and 6' rods	●
Adaptable to R32, T38, T45 drill rods	●
1 x Rear and 1 x front stinger	●
Automatic lubrication for drilling and positioning unit	●

\*T45 speed rods gives 9+1 rods in the carousel

**FEED**

BMHP 6804, 3 141 mm	○
BMHP 6805, 3 448 mm	○
BMHP 6806, 3 753 mm	○

**AIRSYSTEM/WATERSYSTEM**

Air flow guard	●
Compressor: Atlas Copco LE7	●
Hydraulic water booster pump, max capacity at 12 bar boost 60 l/min. Minimum water inlet 2 bar	●
Water hose reel including hose	○

**HYDRAULIC SYSTEM**

Low oil level indicator	●
Oil temperature gauge on oil tank	●
Water/Oil cooler in stainless steel	●
Filtration 16 µm	●
Oil filter indicator	●
Mineral hydraulic oil	●
Electrical oil filling pump	●
Heater kit for hydraulic oil tank	○
Biodegradable hydraulic oil	○
Ni-Cr plated piston rods (limited selection on request)	○

**ELECTRICAL SYSTEM**

Total installed power 80 kW (Main motors 1x75 kW)	●
Voltage 380-1 000 V 50/60 Hz	●
Starting method star/delta (400-690 V)	●
Starting method - soft start (not for 1 000 V)	○
Electronic overload protection for electric motors	●
Digital voltmeter/amperage meter in electric cabinet	●
Switch gear	○
PC4 or PC5 Plug/Socket	○
Phase sequence and eart fault indicator	●
Battery charger	●
Stainless steel electrical enclosure	○

**DRIFTER RODS/PIPES**

Rock drill	Rod/Pipe	Guide tubes	Hole diameter (mm)
COP 1838+	R32 Speedrod	N/A	51-64
COP 1838+ MUX+	T38 Speedrod	TDS 56	64-76
COP 1838+ MUX+	T45 Speedrod*	TDS 64	64-76

Recommendations are given for surrounding temperature of 40 °C and up to a height of 2 000 m

**CARRIER**

Deutz BF4L 914, 72kW Stage II/ Tier 2	○
Deutz D914 L04, 55kW Stage IIIA/ Tier 3	○
Deutz TD 3.6 L04, 55kW Stage IIIB/ Tier 4i	○
Front axel DANA Spicer 123/90	○
Rear axel DANA Spicer 123/90 ±8° oscillation	○
Articulated steering ±40° steering angle	●
Four-wheel drive	●
Electric system 24 V	●
Batteries 2x12 V, 70 Ah	●
Automatic differential lock on front axle, limited slip	●
Tires 9.00 x R20	●
Tramming lights 6 x 40 W LED, 2 x 80 W, 24 V DC	●
Working lights 4 x 80 W LED, 24 V DC	●
Illuminated stairs for platform LED	●
Front and rear jacks	●
Fuel tank, volume 60 L	●
Fire suppression system ANSUL (manual, checkfire or automatic)	○
Rig washing kit*	○
Manual lubrication kit	○
Boot washing kit*	○

\*Not applicable when equipped with dry drilling system

**CONTROL SYSTEM**

Direct Control System	○
Atlas Copco Rig Control System	○
Angle Reading Instrument (ARI)	○
Angle Reading Instrument (ARI) with hole depth measurement	○
Breakthrough Automatic Stop	○
Underground Manager pro	○
Drill plan handling	○
Void Detection	○
Automatic Parallel Holding	○
Rig Remote Access (RRA)	○
Mobile Tele Remote/Multi Tele Remote	○
Remote operating kit	○
Remote controlled camera on tripod with monitor in cabin	○
Total Station Navigation	○

**CABIN (OPTIONAL)**

ROPS and FOPS approved cabin, noise level <80 dB(A)	●
Swingable seat for drilling and tramming	●
Front window 22 mm (P8B safety classified)	●
12 V Outlet	●
Medioplayer	○
Air condition	●
Electrical heater, 1.2 kW, 230 V (CE)	○
Manual spotlight 70 W (Left and right)	○

**PROTECTIVE ROOF**

FOPS approved	●
Stainless steel	○
Manual spotlight 70 W (Left and right)	○
Swingable seat for drilling and tramming	○

**RECOMMENDED CABLE SIZE AND LENGTH**

Voltage	Type	Dimension (mm <sup>2</sup> )	Diameter (mm)	Length (m)
380-525 V	Buflex	3x70+3G16+2x1.5	37	110
550-575 V	Buflex	3x50+3G6+2x1.5	32	150
660-690 V	Buflex	3x35+3G6+2x1.5	28	200
1 000 V	Buflex	3x35+3G6+2x1.5	28	200

Recommendations are given for surrounding temperature of 40 °C and up to a height of 2 000 m



## ***SAFETY, PRECISION AND FLEXIBILITY***

The Boom mounted drill unit increases flexibility and precision while the operator-friendly work environment ensures safety and worker satisfaction.

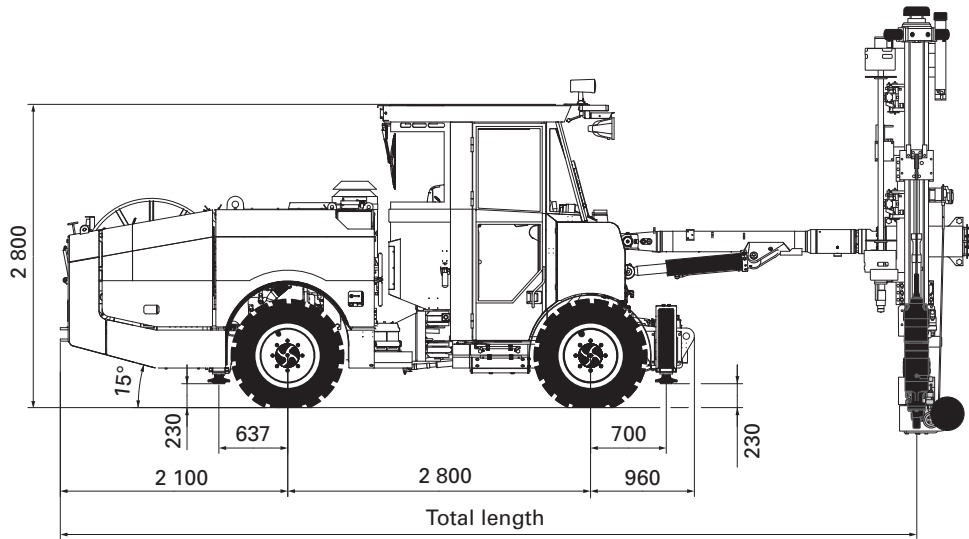

Sideview

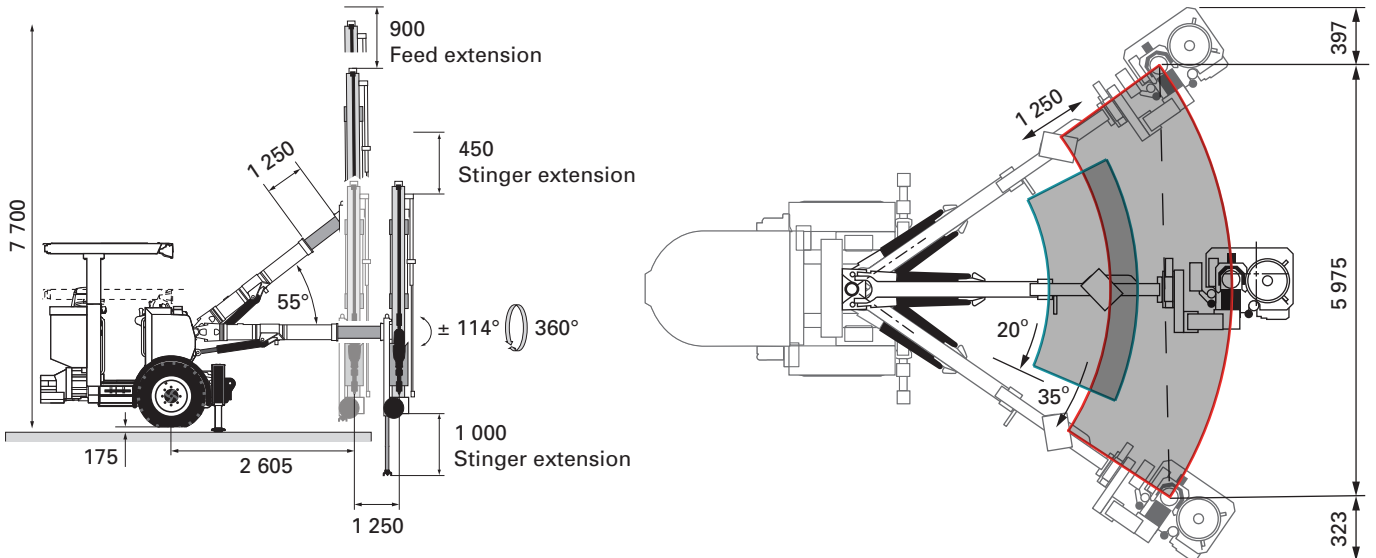

Coverage area

**DIMENSIONS**

Measurement	
Width	2 100 mm
Height tramming, roof up/down	2 800 / 2 100 mm
Length tramming (with BMHP 6804/05/06)	9 300*/9 600*/9 900* mm
Ground clearance	365 mm
Turning radius outer/inner	5 000/2 850 mm
*+200 mm with extractor	

**GROSS WEIGHT (DEPENDING ON CONFIGURATION)**

Total	13 500 kg
Boom side	9 000 kg
Engine side	4 500 kg

**TRAMMING SPEED**

On flat ground (Rolling resistance 0.05)	>15
On incline 1:8	>5

**NOISE AND VIBRATION**

Operator sound pressure level in canopy, drilling, free field (ISO 11201)	106±6 dB(A) re 20uPa
Operator sound pressure level in cabin, drilling, free field (ISO 11201)	75± 3 dB(A) re 20uPa
Operator sound pressure level working close to machine, drilling, free field	106±6 dB(A) re 20uPa
Sound power level (ISO 3744), drilling, free field	126 dB(A) re 1pW
Vibration levels seated, drilling (ISO 2631-1) Cabin	0.07± 0.07 m/s <sup>2</sup>
Vibration levels standing, drilling (ISO 2631-1) Cabin	0.07±0.07 m/s <sup>2</sup>
Vibration levels seated, drilling (ISO 2631-1) Canopy	0.1±0.15 m/s <sup>2</sup>
Vibration levels standing, drilling (ISO 2631-1) Canopy	0.1±0.15 m/s <sup>2</sup>

## ***COMMITTED TO SUSTAINABLE PRODUCTIVITY***

We stand by our responsibilities towards our customers,  
towards the environment and the people around us.

We make performance stand the test of time.  
This is what we call – Sustainable Productivity.

[www.atlascopco.com](http://www.atlascopco.com)

The Atlas Copco logo consists of the brand name "Atlas Copco" in a stylized, italicized serif font. It is positioned between two thick, horizontal blue bars that serve as a frame for the text.