



# SPECIFICATION SHEET



## R9 JAW CRUSHER

R-Version

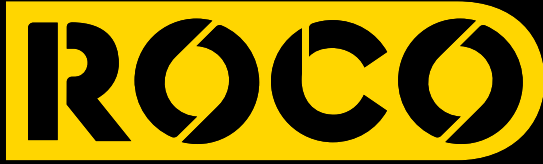

## R9R Jaw Crusher

### ROCO R9R Jaw Crusher

- ROCO R9R Jaw Crusher is suitable for use in all quarry, mining, demolition & recycling industries.
- The mobile crushing unit ROCO R9R is determined for crushing non-sticky, medium hard or hard building waste, concrete, concrete blocks or natural aggregates such as limestone, sandstone & similar materials up to compressed strength of 200MPA.
- The ROCO R9 Jaw Crusher is equipped with a 800x500mm Jaw opening with full adjustment & central greasing point. 19%MN Jaws + Liners installed (Crusher box and parts produced in the same foundry as Metso Products).
- The Game Changer with the R9 is that it can also work indoors as it has Plug-In facility meaning it can be powered completely from permanent 3 phase power supply or by existing generator on site, meaning no fumes and silent operation indoors or out! Ideal for working indoors at dusty recycling centres, the Healthy & Eco-friendly option!
- Extremely Economical crusher with a very low fuel consumption of only 7-9 litres of fuel per hour or no diesel fuel consumption when 3PH Plug-In is being used!
- Turbo Diesel engine operating onboard 100KVA Leroy Somer Generator with extra 63A, 32A & 230V auxiliary plugs installed for driving an extra conveyor, screenbox or carrying out Repairs on site without the use of an extra power source. All drives are electric with built in motors on the conveyor/ Drums.
- The ROCO R9R Jaw Crusher is Irish designed to the highest standards with the operator in mind & will guarantee the crushing of materials with ease and most efficiently. Attention to detail on Design & Quality on the R9 is unrivalled in the 20 Ton Crusher Market.
- Steel iron Bender/Apron installed to the base of the Swing Jaw (Unique to ROCO) so that Steel & Re-bar in concrete will get bent & will not damage the discharge belt while in the jaw and getting crushed.
- Hydraulic Folding Side conveyor (Optional Extra) complete with pre screen and mesh size of your choice installed, also by pass chute installed if Side Conveyor not required for more tonnes per hour production. Overband magnet installed over discharge Conveyor (Optional Extra) for separating steel from crushed material and is ideal for feeding into steel skip for metal recycling.

- Average output of 30-120TPH/33-132(US) and fast on site setup time of just a few minutes, CSS setting of 30mm.
- Onboard built in Hydraulic powerpack that operates the Tracking and working of hydraulic Cylinders.
- Dust suppression system (Optional Extra) with filtration for dust control (Water Jets) ready for hooking up to your water main on site. Spray bars + jets installed to Crusher Feed, Under Crusher Box & on End of Main Discharge Conveyor.
- Compact machine yet all panels for maintenance open fully and floor on catwalk lift up for any maintenance procedures, Extremely easy access to all main components.
- All components including necessary guards, access platform, lockable tool box, switchboard & necessary wiring system are all located on the tracked undercarriage which provides easy unit movement.
- Machine fully Earthed & complete with Earth Rod (To Avoid Electrocution in the event of electric fault on board).
- As the ROCO R9R Jaw Crusher is just under 20 Ton and 2.5M wide it is easily transported & not restricted around sites. It can be hauled on a Standard Trailer, Curtainsider, Mega Trailer or Low Loader Without Road Permits.
- CE Certified/Declaration of conformity available.

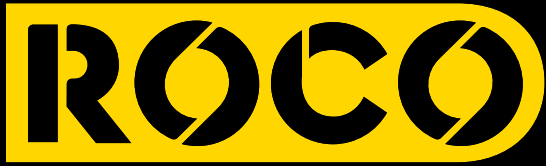

## R9R Jaw Crusher

### Working Dimensions R9R-Version

**Length:** 10.616m / 34.8ft

**Width:** 5.3m / 17.3ft

**Height:** 2.98m / 9.7ft

### Transport Dimensions

**Length:** 10.616m / 34.8ft

**Width:** 2.5m / 8.2ft

**Height:** 2.98m / 9.7ft

**Weight:** 19,500KGS / 42,990(LBS)

### Crusher Box

**Reverse Crush Option:** Yes Installed as Standard (Ideal for crushing Ashfelt)

**Single Toggle:** Yes

**Max Opening:** 800x500mm

**Min Setting (CSS):** 30mm

**Max Setting (CSS):** 150mm

**Crusher Strength:** 200MPa

**Crusher Drive:** Electric Motor/V-Belts

- Jaw Plates are Top Quality 19%Mn Reversible Plates, 1 x Toothed + 1 x Smooth Installed as standard (Best Suited for Recycling). Variable Choice of Jaw Plates on Request.
- Crusher Liners are Top Quality 19%Mn (6 No) All Replaceable Wear parts.

## Grizzly Feeder/Hopper

**Length:** 3,150mm

**Width:** 710mm (Base Table)

**Max Size of Feed Material:** 500 x 400mm

**Grizzly Gap:** 27-50mm (Replaceable)

**Length of Grate Area:** 1,270mm

**Weight:** 1,350kg (Table)

**Drive:** 2 PC's, MVE2100 Electric Variable Speed Motors

**Remote Control:** 150m Range

**Material:** Top Quality Hardox Lined Hopper & Replaceable Hardox Wear plates installed to Feeder Floor.

## Main Conveyor

**Length:** 8,300mm

**Width:** 800mm

**Drive:** Electric Drum Interroll 4kW 0 240mm 1.25m/s

## Side /Pre Screen Conveyor

**Length:** 2,800mm

**Width:** 500mm

**Hydraulic Folding:** Yes

**Drive:** Electric Drum Interroll 1.5kW 0 220mm 1.25m/s

## Engine

**Manufacture:** Perkins 1104 C4.4

**Engine Power:** 103KW / 138HP – 1500RPM

**Engine Cooling:** Large Radiator & Oil Cooler



## R9R Jaw Crusher

### Generator

**Manufacture:** Leroy Somer LSA 44.3 S4 C6/4

**Generator Power:** 100KVA (Standby) —90KA Continuous

**Volts:** 400, 50HZ

**KW:** 79/72 Continuous

### Hydraulics

- Electric Driven Power pack built on board—Only activated when required.
- No Hydraulics in use when machine is crushing/working meaning no chance of hose bursting, oil contamination or pollution on site when crushing.

### Undercarriage

**Manufacture:** Strickland

**Sprocket/Idler Centre:** 3,000mm

**Overall Width:** 2,250mm

**Shoe Width:** 400mm

**Drive:** Hydraulic Motor

**Maximum Travel Speed:** 1.2km/hr

**Weight:** 2,600kg

### Tracking

**Wireless Remote:** Yes (150m Range)

**Emergency Stop:** Yes

**Travel Alarm:** Yes

## Electrics

<b>Emergency stops:</b>	5 installed
<b>Start Siren:</b>	Yes—10 Second Delay
<b>Flashing Beacon:</b>	Yes Beacon & Siren Alarm for Track Manoeuvring
<b>Safety Switches:</b>	Yes Installed for Oil Temperature, Coolant Level, Hydraulic Oil Level and Engine Speed.
<b>Earthing:</b>	Machine fully Earthed & Complete with Earth Rod preventing Electrocutation in the event of fault.

- Fully Waterproof & Dust proof Electric Cabinet complete with heater to prevent Dampness/ Condensation in Electric Compartment.
- All Trip Switches & Cables labelled.
- Safety sensors installed to Electric Cabinet Doors.

## Safety Features

- Protector Guard over Jaw to prevent loose stones jumping out or persons falling in.
- Emergency Stops— 5 in Total
- Work Lamps (Optional Extra).
- Chevron Stickers + Safety Decals.
- Safety Guards on Return Rollers.
- Cat Walks & Fixed access Ladder/Step. All access doors lockable.
- Full Diagnostics, Fault Findings on Monitor, including Greasing Intervals.
- GPS (Optional Extra) Remote messages Notifying any Faults or issues on board.
- Machines fully Earthed & Complete with Earth Rod Preventing Electrocutation in the Event of Electric Fault. All functions Fused & Trip Switches installed.
- Isolator/Dead man switch installed preventing Starting or Powering up when not required or carrying out Maintenance.
- Complete with full User & Part Manuals (Various Languages Available).
- Sensors on Electric Cabinet indicating when doors not closed.



## R9R Jaw Crusher

### Remote Control

- Wireless Remote Control.
- Handheld, Lightweight and Easily stored in Excavator or Wheel Loader.
- Complete with Waist Band when Operator is Tracking machine while walking.
- 2 Speed Tracking.
- Full Control of Feeder Speed.
- Activation button for Hydraulic Power pack.
- 150 Range with Emergency Stop Installed.

### Optional Extras at Additional Cost

- Steel Iron Bender/Apron on base of the Jaw to Bend Re-Bar in Concrete & Not Damage the Discharge Belt. (Installed as standard on R9R only).
- Folding Side/Dirt Conveyor for Pre Screening & Producing another Product.
- Overband Steel Magnet.
- Dust suppression system with filtration for dust control (Water Jets) ready for hooking up to your water main on site. Spray bars + jets can be installed to Crusher Feed, Under Crusher Box & on End of Main Conveyor.
- Central Greasing Point (Installed as Standard).
- Reverse Crusher option (Installed as Standard).
- Fully Automatic Greasing Station.
- Work lamps.
- GPS Complete with Smartphone Capability to Locate Machine + Reporting of any issues, Service Intervals or problems on Board via Message System.
- Weigh loader (Scales) for Calculating/Weighing Crushed Material + Printer—Which is also Smartphone Friendly.
- Personalised Company Decals Fitted.
- Lockable Tool Box comes complete with required Spanners, Extra Shims for Crusher Box (6 No) & Grease Gun (All Complete as Standard).

## Transport Position

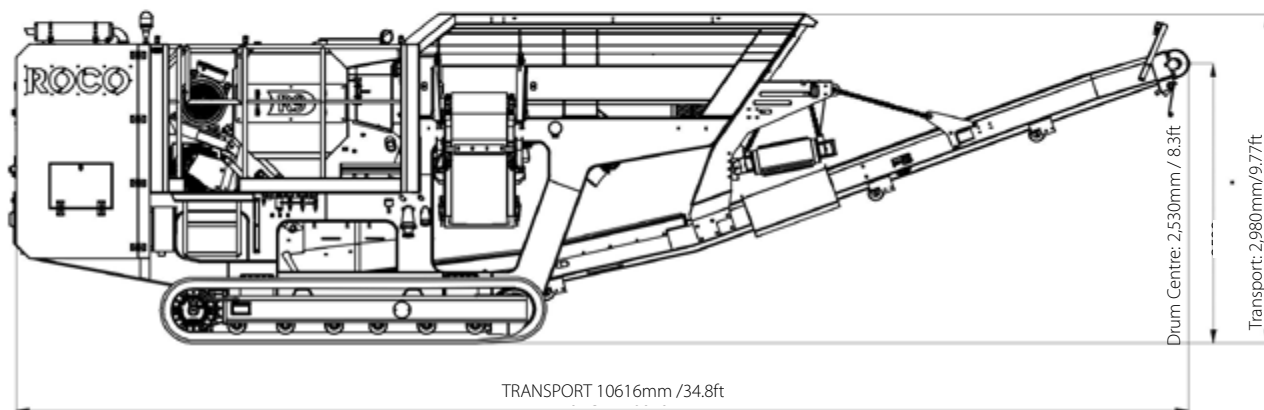

Weight: 19,500 kgs/42,990lbs (Full Spec)

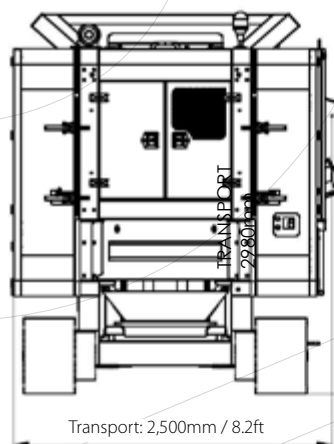

**Suitable for Transporting & Shipping Worldwide by Standard Trailer, Curtainsider, Mega Trailer, Low Loader or Ro-Ro. No Road Permit Required (Only 2.5m/8ft wide)**



# R9R Jaw Crusher

## Working Position

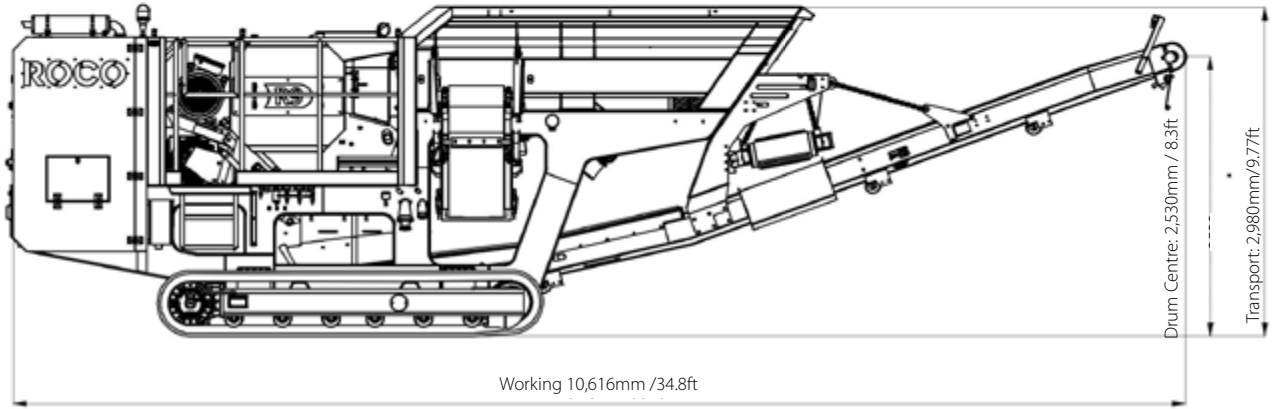

Weight: 19,500 kgs/42,990lbs (Full Spec)

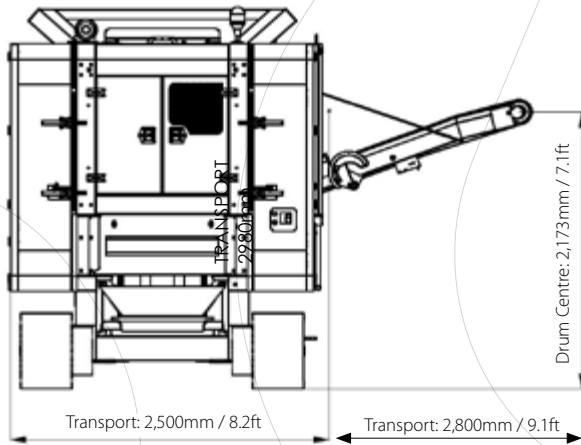

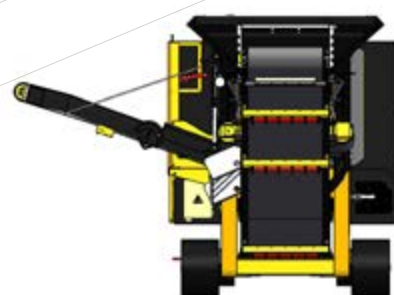
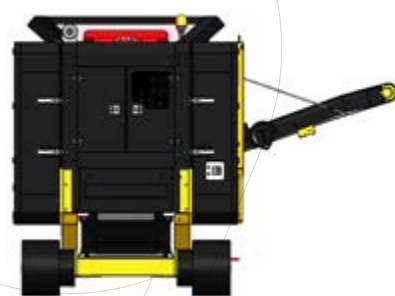

# ROCO

BY  BALLYTRAIN

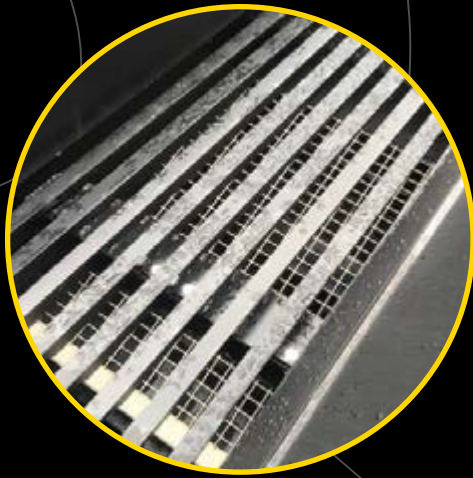

205A Concession Road  
Crossmaglen, Newry  
Co. Armagh, Northern Ireland  
BT35 9JD

T +44 28 30868833

E [sales@roc9.com](mailto:sales@roc9.com)



[www.roc9.com](http://www.roc9.com)