

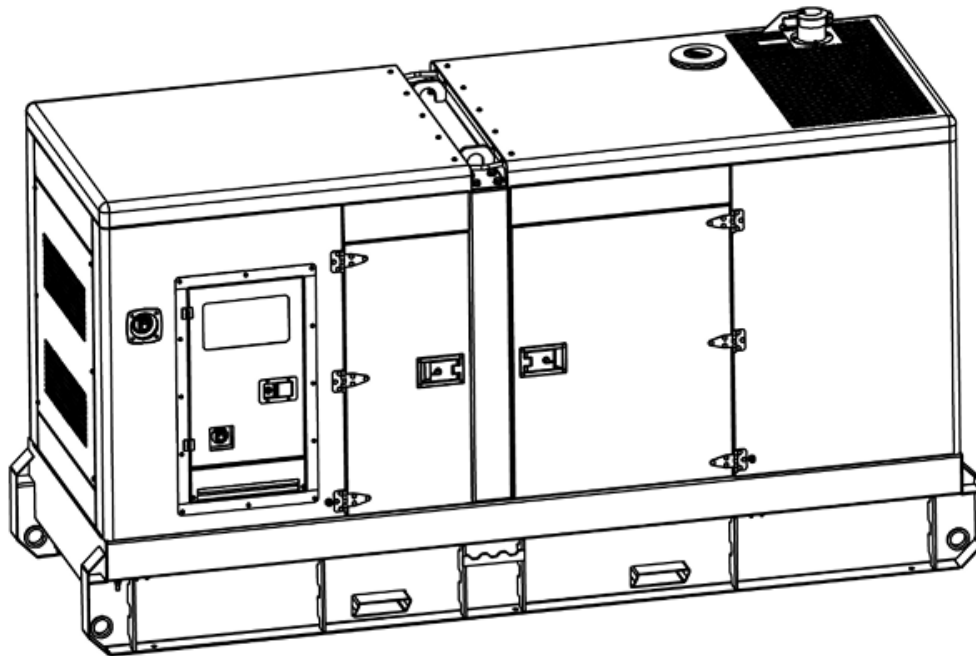

DPX-20017 - Perkins 2206C-E13TAG3 - 440 kVA

DIESEL GENSET SPECIFICATION

400kVA (PRP) / 440kVA (ESP)



Diesel Genset Specification

WPS400S

General technical data

Model	WPS400S	Rated voltage V	Current A
Structure	R	380	607.8
Prime power (PRP): kVA / kW	400 / 320	400	577.4
Standby power (ESP): kVA / kW	440 / 354	415	556.5
Frequency: Hz	50	440	524.9
Rotate speed: RPM	1500		
Phase: P	3		
Power factor: $\cos\phi$	0.8	Load	Fuel consumption L/h
Protection class	IP54	25%	N/A
Noise level: dB@7m	71.3	50%	46
Tank capacity: L	800	75%	65
Dimensions: mm	4392×1423×2512	100%	85
Dry weight: kg	4555kg	110%	94

Main Features

Advantage	Design Standards	Environmental Operating Conditions
<ul style="list-style-type: none"> • Low fuel consumption • Optimized system • High reliability • High availability 	<ul style="list-style-type: none"> • Conformance Européenne (CE) • ISO8528-5:2022 • AS 3000-2018 • AS 3010-2017 	<ul style="list-style-type: none"> • Installation place: outdoor / indoor (well ventilated). • Ambient temperature: -25°C to 45°C (the coolant heater is needed when the temperature is below 5°C) • Humidity: Less than 80% • Altitude: Below one thousand (1000) meters.
Factory Inspection	Service Support	Performance Guarantee
<ul style="list-style-type: none"> • Protection devices working test • Starting ability in normal temperature • 50% rated power load moment capability • Load test :0, 25%, 50%, 75%, 100%, 110% 	<ul style="list-style-type: none"> • Global product service support 	<ul style="list-style-type: none"> • Product design, manufacturing and performance have been verified by standards • Generator set has passed transient response test according to ISO8528-5 • Both engine and alternator have passed prototype factory testing.

Diesel Genset Specification

WPS400S

Power System

Engine

Manufacturer / brand	Perkins	Intake system	Turbocharged
Model	2206C-E13TAG3	Intake resistance: kPa	3kpa
Cylinders	6	Exhaust back pressure: kPa	≅8kpa
Bore: mm	130	Oil capacity: L	40L
Stroke: mm	157	Coolant capacity: L	51L
Displacement: L	12.5	Battery voltage: V	24v
Compression ratio	16.3:1	Dimensions: mm	2410×1120×1725
Rotate speed: RPM	1500	Dry weight: kg	1478kg
Prime power: kWm	368		
Standby power: kWm	413		
Governor	EFC		
Type of fuel Injection	Direct		

Alternator

Manufacturer / brand	Leroy-Somer	Insulation class	H
Model	LSA47.3S4	Temperature rising class	H
AVR	R250		
Exciter	Standard self-excitation, SHUNT	Protection class	IP23
Windings	100% copper	Voltage regulation	±0.5%
Winding pitch	2/3	Total Harmonic Distortion THD	<1.5%
Number of poles	6		
Terminals	12		

Control System

Brand	Deepsea Electronics
Model	PLC920/DSE7420MKII

General Functions

- Automatic start / stop control
- Manual/remote start control
- Automatic Mains Failure (AMF)
- Real time monitoring and display of multiple parameters
- RS232, RS485 interface and Ethernet can be used simultaneously
- CAN and Modbus communication
- Provide complete control solutions

Monitoring and protection

Oil pressure	Over load
Water temperature	Over current
Rotate speed	Over voltage
Start	Under voltage
Running time	Over frequency
Battery voltage	Under frequency

Product Appearance

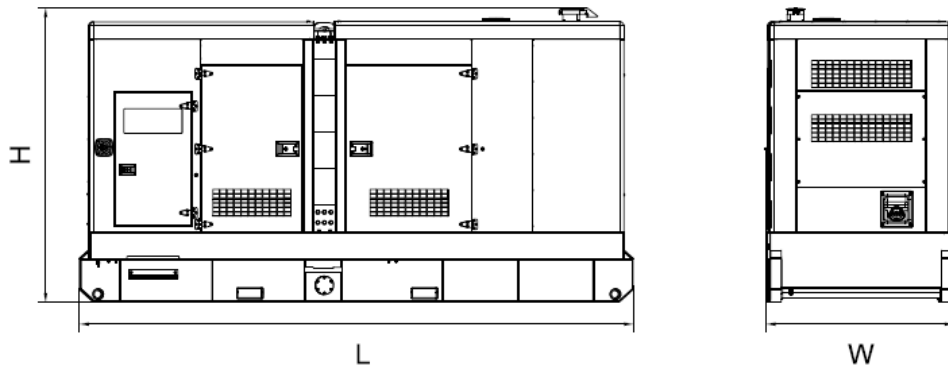
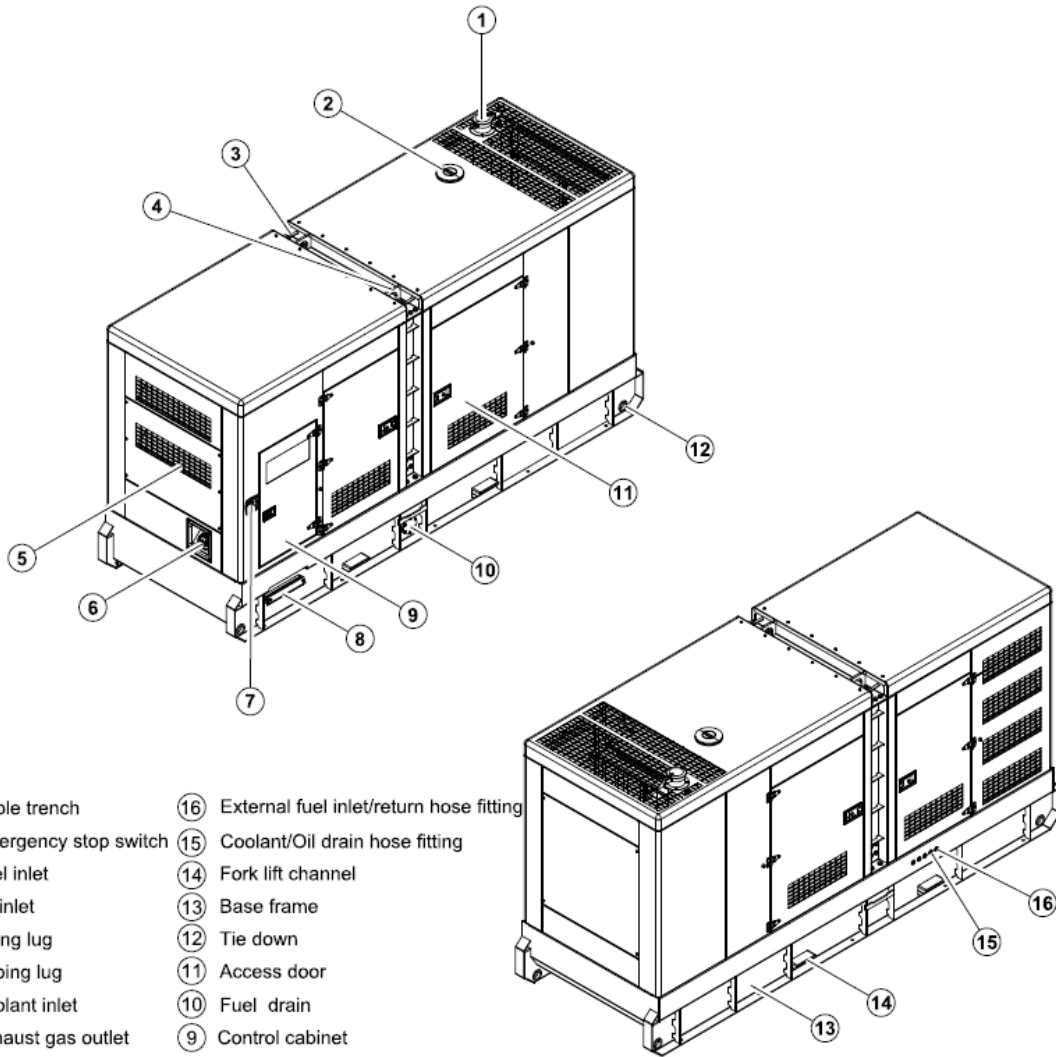

Diesel Genset Specification

WPS400S

Product Configuration

Standard configuration

Engine	Generator	Control switchgear	Canopy (sound-proof)	Base Frame
Electric starter motor	Alternator	PLC control system	SECC Electrogalvanized sheet	Steel base frame
Battery system	H class insulation	Main circuit breaker	Corrosion-resistant coating	Engine bracket
Speed control system	H class temperature rising	Breaker cabinet	Access door	Alternator bracket
Turbocharger	IP23 protection	Communication connector	Stainless steel hinge	Radiator bracket
Lockable isolator switch	AVR voltage regulator	ATS connector	Sound absorbing cotton	Vibration isolators
Battery charger		Mains floating charger		
Fuel system	Lubrication system	Cooling system	Intake / exhaust system	Service documents
Base frame fuel tank	Oil pressure sensor	50°C radiator	Air filter	Installation and operation manual
Fuel level sensor	Oil temperature sensor	Water level sensor	Exhaust muffler	Test report
Flexible connection pipe	Oil filter	Intercooling pipe	Exhaust bellow	Circuit diagram
Fuel filter	Manual oil drain pump		Exhaust pipe and flange	Warranty manual
Fuel filler	Oil drain ball valve		High temperature protective sleeve	Engine operation and maintenance manual
				Standard package

Optional configuration

Engine	Alternator	Control switchgear	Fuel system	Lubrication system
Jacket water preheater	Anti-condensation heater	ATS cabinet	Fuel three-way valve	Electric oil drain pump
Oil preheater	Treatments against humidity and corrosion	Paralleling control system	Daily fuel tank	
		Grid-connection system		

Power Class Definition

- Prime Power (PRP): the unit runs continuously with variable load, the number of operating hours is not limited, and 1h overload 10% operation is allowed per 12h, and the average load factor is less than 70% per 24h.
- Standby Power (ESP): operating time does not exceed 500h per year, continuous operating time does not exceed 300h, the average load factor is less than 80% per 24h. Overload operation is not allowed.

Product Statement

- The data of specifications is based on the following standard environmental test conditions.
 - Ambient temperature 25°C
 - Altitude 100m
 - Relative humidity 30%
- Dimensions, weight and other parameters are for reference only, which shall be subject to the final design drawing.

Data is subject to change without prior notice as new products are always developed.