

ITEM NO.	PART NUMBER	DESCRIPTION	QTY.
1	CARGO SHIPPING 20FT CONTAINER	CARGO SHIPPING 20FT CONTAINER	1
2	MD.21.24.05.05	EXHAUST COVER	1
3	MD.21.24.08A	MB20 ADDITIONAL EXHAUST	1
4	MD.21.24.08C	PRE-CLEANER MNT ASM	1
5	MD.21.24.08D	AIR INTAKE MNT ASM	2
6	MD.21.24.10.01	LOUVER PANEL	1
7	MD.21.24.10A	BULKHEAD BRKT ASM	1
8	MD.21.24.10.04	COVER PLT	1
9	MD.21.24.10.07	EXHAUST MNT BASE	1
10	MD.21.24.10.08	EXHAUST MNT PAD	1
11	MO 919 Ø152	EXTERNALLY MOUNTED DYNAMIC ENGINE AIR PRECLEANER	3
12	GPSC.B.75	0.75T BOW SHACKLE	4
13	MD.WR.10.3633	1.1T STEEL ROPE C/W SWAGED LOOP ENDS	4
14	TBJJ10X6	0.54T JAW/JAW TURNBUCKLE	4
15	G10HLSHR12	1T HEAVY LIFT SWIVEL HOIST RING	4

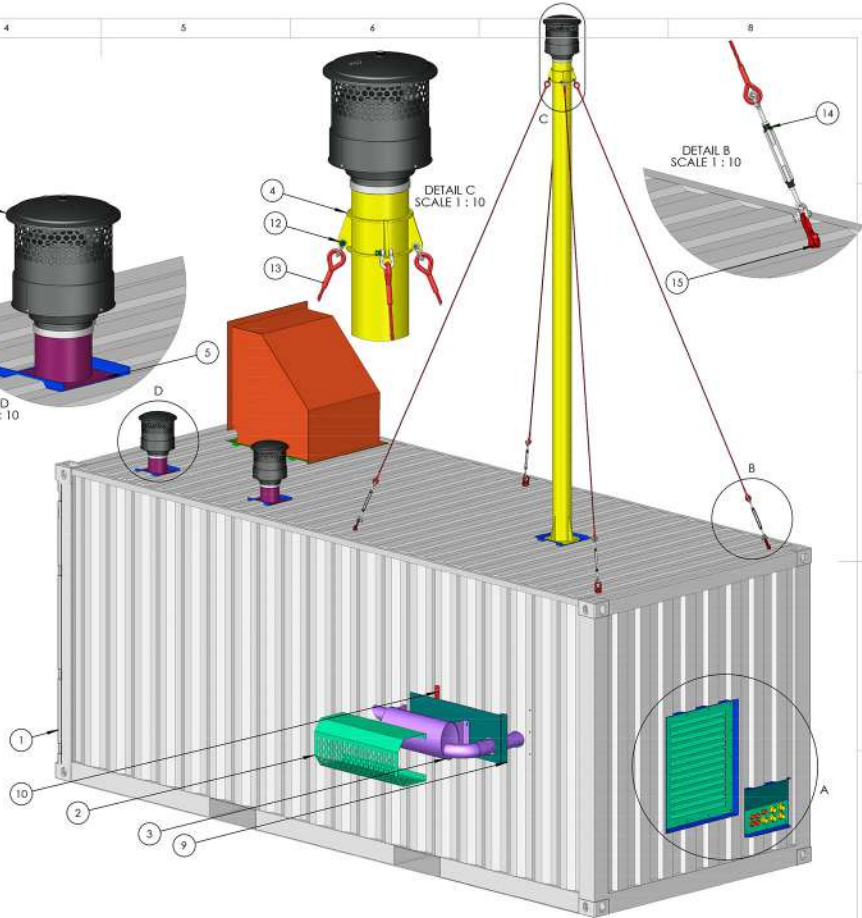
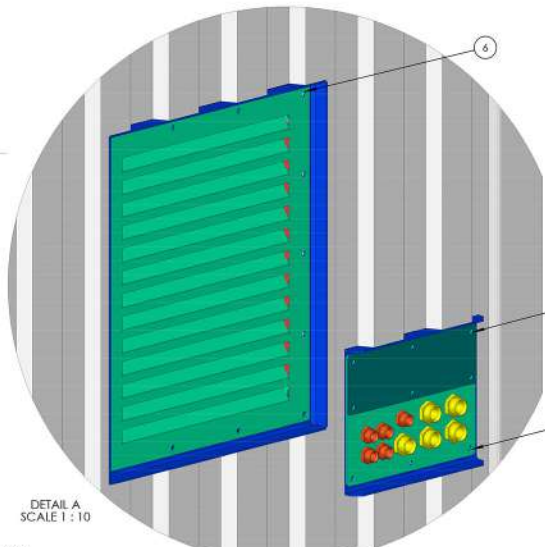
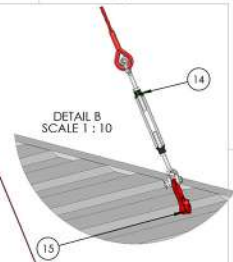
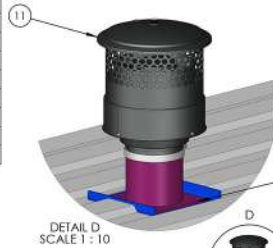

CONCASSAGE
CRIBLAGE
LAVAGE
RECYCLAGE

sasYcARE
Le Moulin Des Buis 89120 LEUGNY
03 86 41 14 14
g@grouppe-ycare.fr

UNLESS OTHERWISE STATED
TOLERANCES ARE:
Machining: up to 100mm ± 0.15mm
100 to 300mm ± 0.4mm
300 to 1000mm ± 0.8mm
over 1000mm ± 1.5mm
angles ± 0.25°
Fabrication: up to 500mm ± 1mm
500 to 2000mm ± 2mm
over 2000mm ± 3mm

Remove all burrs and sharp edges				NEXT PROCESS:		DWG NO.	
A3	NAME	SIGNATURE	DATE			MD.21.24.20FT.GA	
DRAWN	M.S.		24.09.2020	FINISH:		DESCRIPTION	
DO NOT SCALE DRAWING			SCALE:1:30	WEIGHT: -kg		POWER PACK GA	
SHEET 1 OF 4		REV: 00	QTY: 1/MC	3rd ANGLE PROJECTION			

POWER PACK

MDS
mds-inf.net

ITEM NO.	PART NUMBER	DESCRIPTION	QTY.
1	MD.21.24.05.06	VERTICAL COWL PLT	2
2	MD.21.24.05.07	HORIZONTAL COWL PLT	2
3	MD.21.24.05.08	F/W SEP. BRACKET	1
4	MD.21.24.07.05	END PLATE	2
5	MD.21.24.08B	AIR CLEANER PIPE ASM	1
6	MD.21.24.10C	HYDRAULIC CLAMP MNT ASM	1
7	MD.21.24.10.02	HEAT EXCHANGER BRKT	1
8	MD.21.24.11A	HYDRAULIC TANK TABLE	1
9	MD.21.24.11B	FUEL TANK TABLE	1
10	MD.21.24.12A	BATTERY BOX PRE-ASSEMBLY	1
11	MD.21.22.GA	HYDRAULIC TANK GA	1
12	MD.21.23.GA	FUEL TANK GA	1
13	MD.10.03.06	AIR BOX MNT BRACKET	1
14	MA-4-3 HEAT EXCHANGER	HEAT EXCHANGER	1
15	9MK 910 109-101	BATTERY MASTER LOCKOUT SWITCH	1
16	PN 880089	LITTELFUSE LX SERIES POWER DISTRIBUTION MODULE	1
17	10-00548	CUSHYLOAT MOUNTING	4
18	4858027	C7.1 ACERT INDUSTRIAL ENGINE	1
19	4411215	WATER SEPARATOR	1
20	1029025D	AM345 PUMP DRIVE WITH SAE 11.5 HOUSING	1
21	K3VL45B-1N1K5-L0	45CC/REV PISTON PUMP	2
22	030W0B25B34XSN	GRP 3 GEAR PUMP 25CC	2
23	R21208	W3/Z2, SAE B 2 BOLT TANDEM PUMP, 35+1 ICC	1
24	032BG25B34SSN	GRP 3 GEAR PUMP 25CC	1

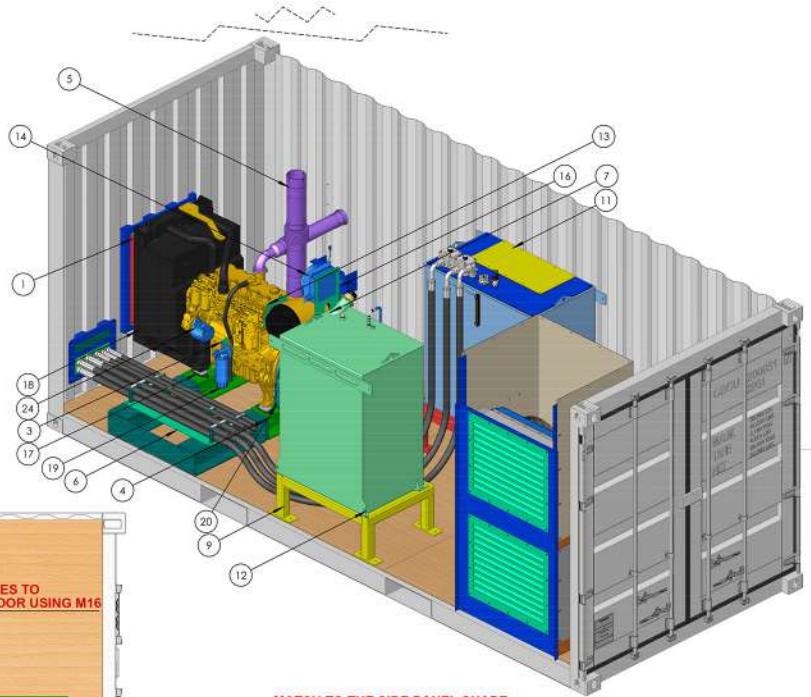
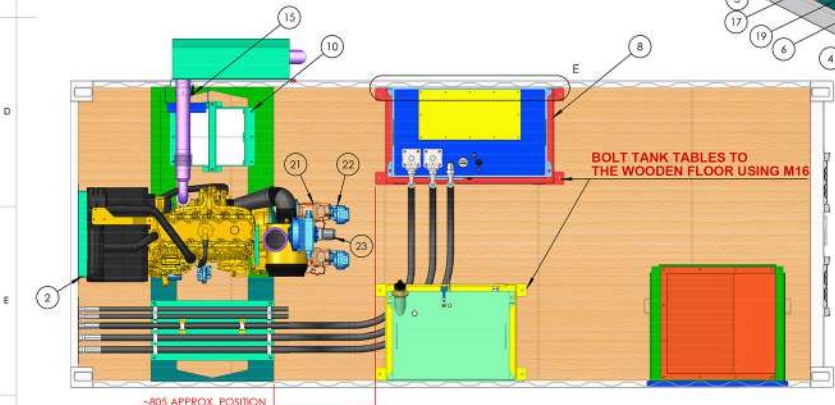

**MATCH TO THE SIDE PANEL SHAPE
DRILL 2No. HOLES FOR M16 WHEN TANK IS IN POSITION
BOLT TANK TO THE SIDE PANEL AFTER
(REPEAT THE OPERATION FOR FUEL TANK)**



M820

CONCASSAGE
CRIBLAGE
LAVAGE
RECYCLAGE

sasYcARE
La Maillon Du Bois 89130 LEUGNY
03 86 44 14 14
g@groupes-yaere.fr

UNLESS OTHERWISE STATED
TOLERANCES ARE:
Machining: up to 100mm ± 0.15mm
100 to 300mm ± 0.4mm
300 to 1000mm ± 0.8mm
over 1000mm ± 1.5mm
angles ± 0.25°
Fabrication: up to 500mm ± 1mm
500 to 2000mm ± 2mm
over 2000mm ± 3mm

Remove all burrs and sharp edges

NEXT PROCESS:

DO NOT SCALE DRAWING

SCALE: 1:30

WEIGHT: --kg

A3	NAME	SIGNATURE	DATE
	M.S.		24.09.2020

CHECKED

DWG NO.	MD.21.24.20FT.GA
DESCRIPTION	POWER PACK GA
SHEET 2 OF 4	REV: 00 QTY: 1/MC

3rd ANGLE PROJECTION

POWER PACK

MDS
mds-int.net

ITEM NO.	PART NUMBER	DESCRIPTION	QTY.
1	MD.21.24.10E	COOLER OUTLET LOUVER PANEL ASM	2
2	MD.21.24.10F	COOLER MNT FRAME	2
3	MD.21.24.10G	COOLER AIR INTAKE CHANNEL	1
4	MD.21.24.10H	COOLER BULKHEAD BRKT ASM	4
5	MD.21.24.10I	LOWER COOLER COVER	1
6	MD.21.24.10J	UPPER COOLER COVER	1
7	MD.21.24.10K	COOLER FRAME SUPPORT	2
8	MD.21.24.10.20	COOLER INTAKE LOUVER PANEL	1
9	MD.21.24.10.25	SINGLE BULKHEAD BLANKING PLT	4
10	BOI-950-3-9-14	TFP COOLER INDUSTRIAL BOL SERIES	2

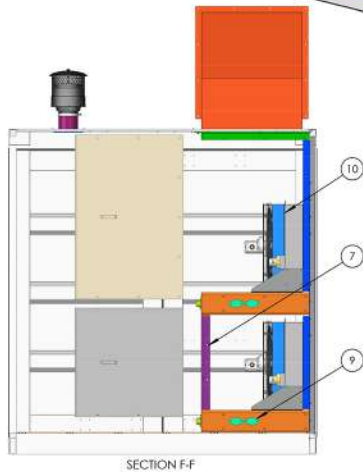
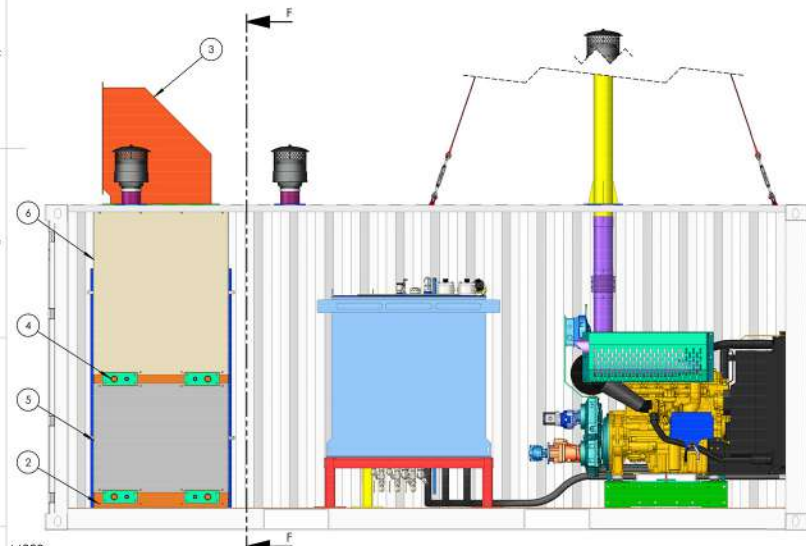
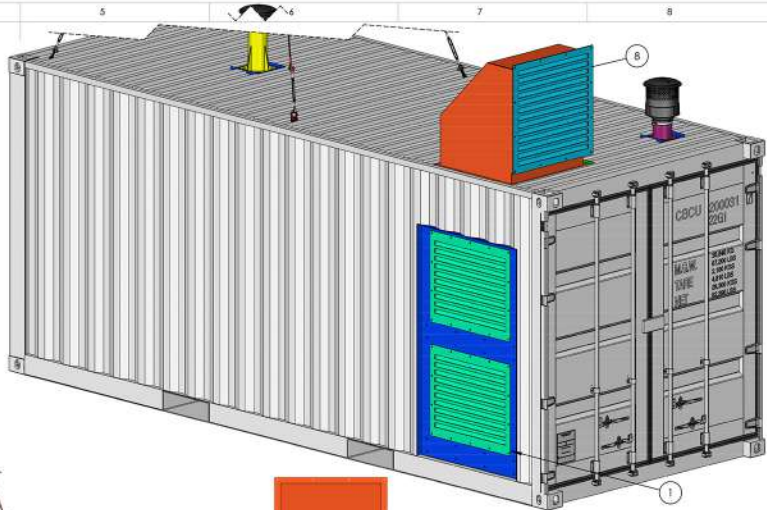

M820

CONCASSAGE
CRIBLAGE
LAVAGE
RECYCLAGE

sasYcARE
Le Moulin Du Bois 89130 LEUGNY
03 86 44 14 14
g@groupe-ycare.fr

ycare

UNLESS OTHERWISE STATED
TOLERANCES ARE:
Machining: up to 100mm ± 0.15mm
100 to 300mm ± 0.4mm
300 to 1000mm ± 0.8mm
over 1000mm ± 1.5mm
angles ± 0.25°
Fabrication: up to 500mm ± 1mm
500 to 2000mm ± 2mm
over 2000mm ± 3mm

Remove all burrs and sharp edges

A3	NAME	SIGNATURE	DATE
	M.S.		24.09.2020

CHECKED

DO NOT SCALE DRAWING

NEXT PROCESS:

FINISH:

SCALE: 1:30

WEIGHT: --kg

DWG NO. MD.21.24.20FT.GA

DESCRIPTION POWER PACK GA

SHEET 3 OF 4

REV: 00

QTY: 1/MC

3rd ANGLE PROJECTION



**CONTAINER PREPARED FOR TRANSPORT
(MAKE SURE ALL BLANKING PLATES ARE IN PLACE AS SHOWN)**

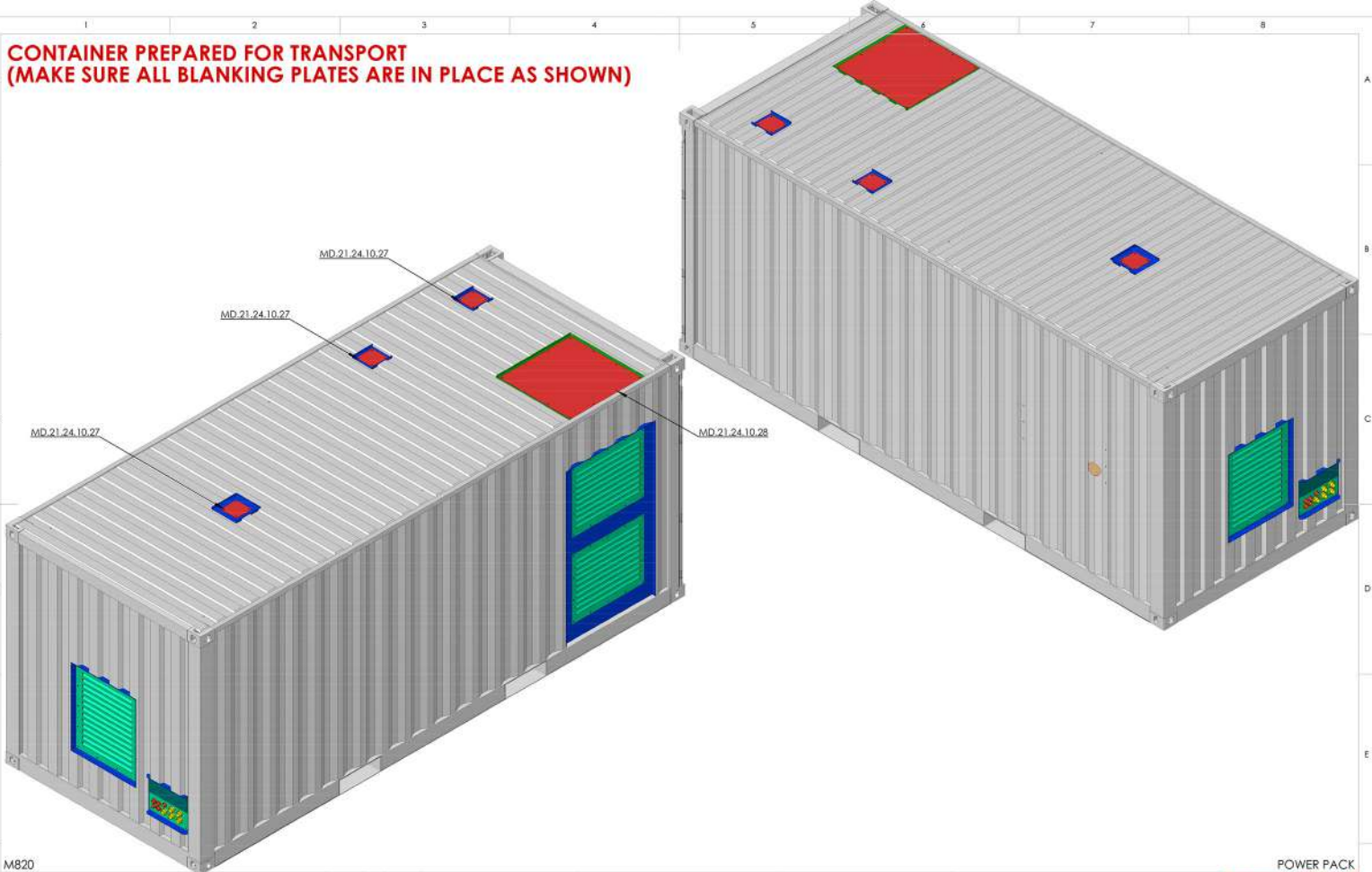

M820

CONCASSAGE
CRIBLAGE
LAVAGE
RECYCLAGE



sasYcARE
Le Moulin Du Bois 89130 LEUGNY
03 86 44 14 14
gc@group-ycare.fr

UNLESS OTHERWISE STATED TOLERANCES ARE: Machining: up to 100mm ± 0.15mm 100 to 300mm ± 0.4mm 300 to 1000mm ± 0.8mm over 1000mm ± 1.5mm angles ± 0.25° Fabrication: up to 200mm ± 1mm 500 to 2000mm ± 2mm over 2000mm ± 3mm				Remove all burrs and sharp edges				NEXT PROCESS:		DWG NO.	
DRAWN	M.S.	24.09.2020	CHECKED	A3	NAME	SIGNATURE	DATE	MD.21.24.20FT.GA			
DO NOT SCALE DRAWING				SCALE:1:30		WEIGHT: -kg		DESCRIPTION			
								POWER PACK GA			
								SHEET 4 OF 4			
								REV: 00			
								QTY: 1/MC			
								3rd ANGLE PROJECTION			

POWER PACK

