

3-WAY SPLIT WORKING ARRANGEMENT BASE MACHINE BUILD

WORKING LENGTH - 15,440 mm / 50' 8"
WORKING WIDTH - 14,557 mm / 47' 9"
WORKING HEIGHT - 4,482 mm / 14' 8 1/2"

WEIGHTS

TIER III ENGINE FITTED - 29,580 KGS
TIER IV ENGINE FITTED - 29,950 KGS

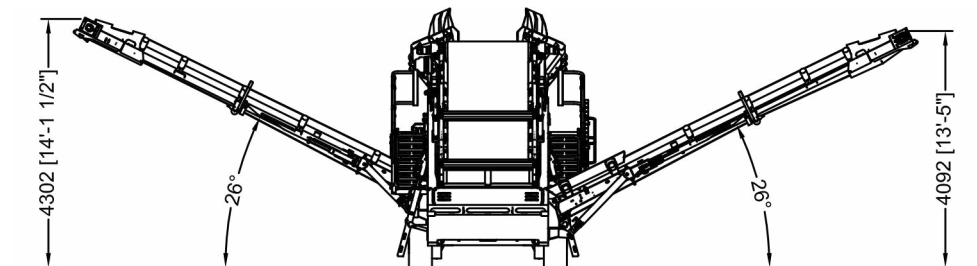
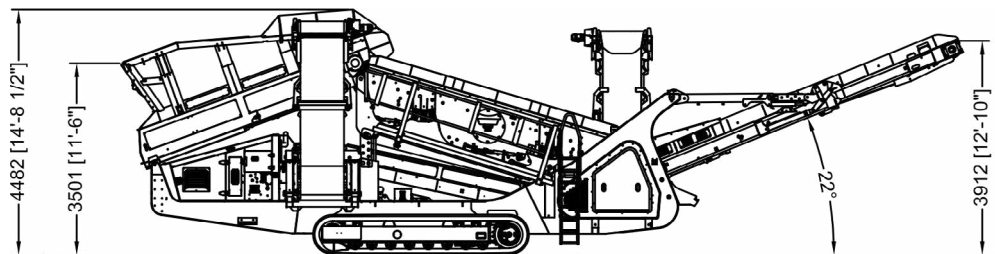

All specifications subject to change without prior notice

3-WAY SPLIT TRANSPORT ARRANGEMENT BASE MACHINE BUILD

WORKING LENGTH - 15,440 mm / 50' 8"
 WORKING WIDTH - 14,557 mm / 47' 9"
 WORKING HEIGHT - 4,482 mm / 14' 8 1/2"

WEIGHTS:

TIER III ENGINE FITTED - 29,580 KGS
 TIER IV ENGINE FITTED - 29,950 KGS

WEIGHT DIFFERENCE WITH OPTIONS FITTED:

- FEEDER WING EXTENSIONS
 (INCL. STABILIZING LEGS) +664 KGS
- DUAL POWER FITTED +1500 KGS
- HARDOX LINERS IN FEEDER BIN +413 KGS

CUBIC CAPACITY - 152 M³

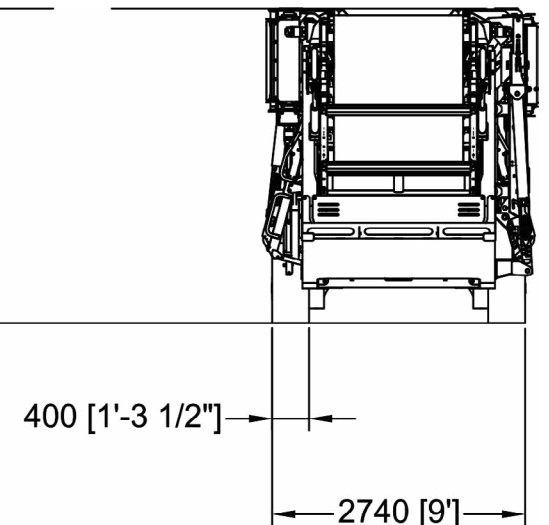
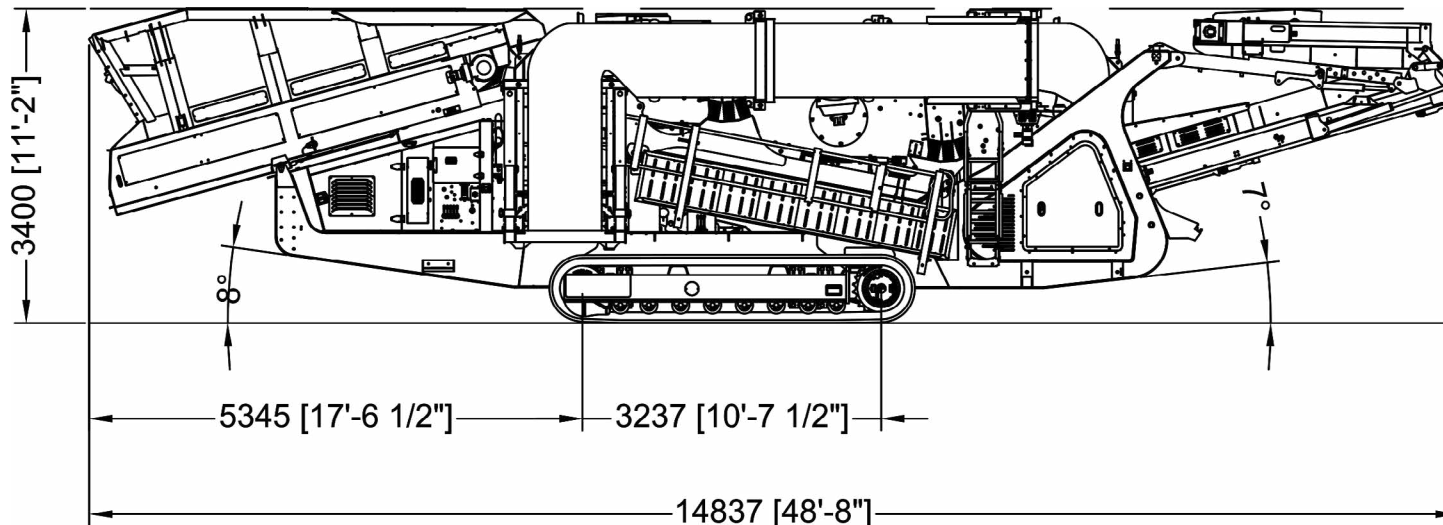
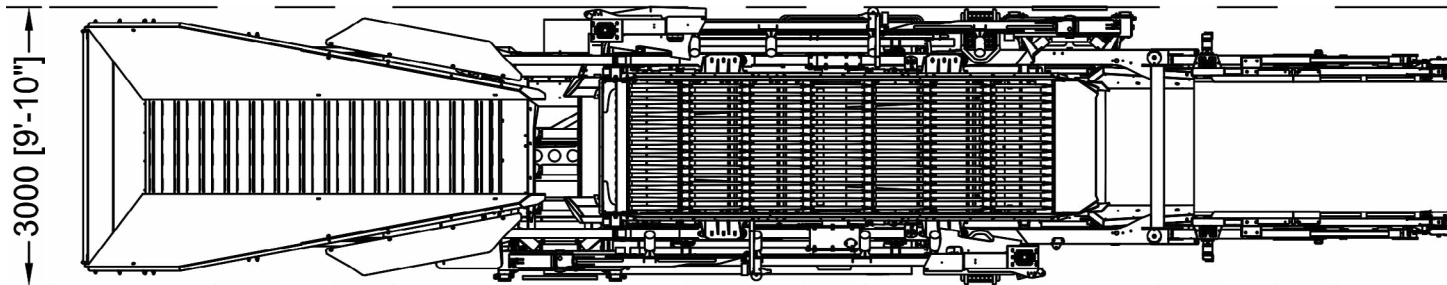

All specifications subject to change without prior notice

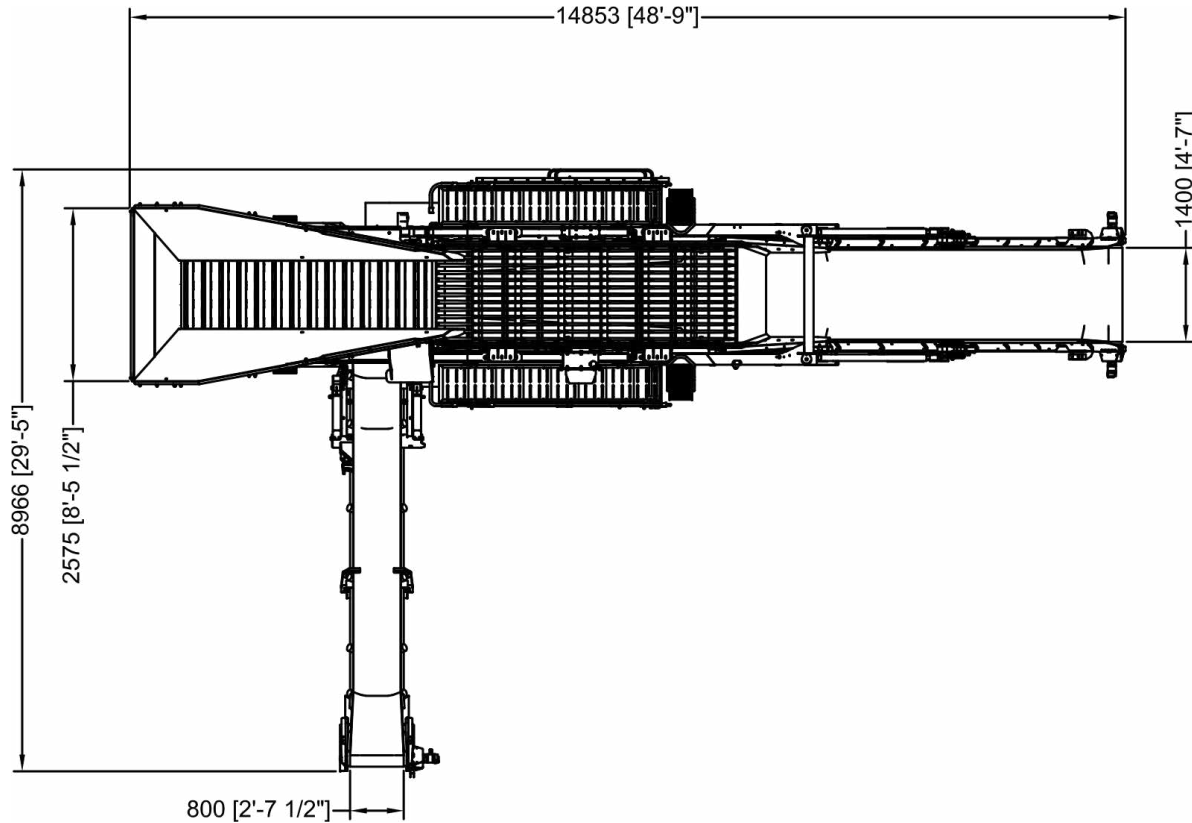

**2-WAY SPLIT
WORKING ARRANGEMENT
BASE MACHINE BUILD**

WORKING LENGTH - 14,853 mm / 48' 9"
 WORKING WIDTH - 8,966 mm / 29' 5"
 WORKING HEIGHT - 4,482 mm / 14' 8 1/2"

WEIGHTS

TIER III ENGINE FITTED - 28,030 KGS
 TIER IV ENGINE FITTED - 28,400 KGS

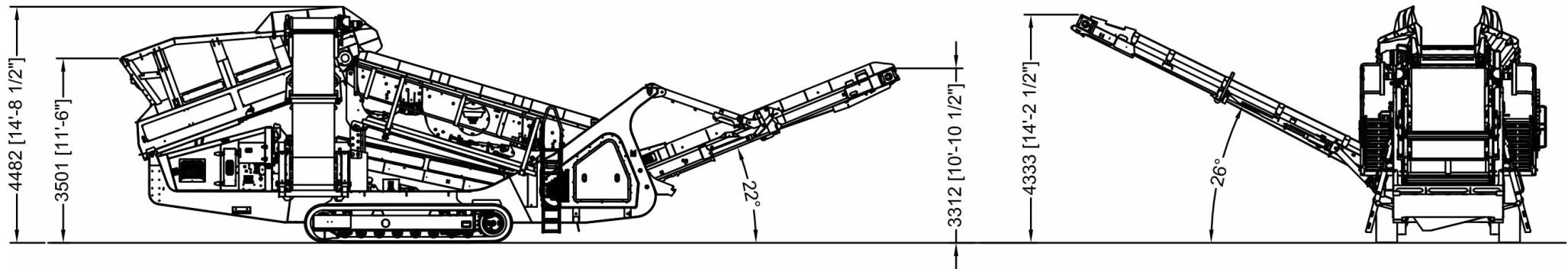

All specifications subject to change without prior notice

2-WAY SPLIT WORKING ARRANGEMENT BASE MACHINE BUILD

WORKING LENGTH - 14,853 mm / 48' 9"
 WORKING WIDTH - 8,966 mm / 29' 5"
 WORKING HEIGHT - 4,482 mm / 14' 8 1/2"

WEIGHTS

TIER III ENGINE FITTED - 28,030 KGS
 TIER IV ENGINE FITTED - 28,400 KGS

WEIGHT DIFFERENCE WITH OPTIONS FITTED:

- FEEDER WING EXTENSIONS
 (INCL. STABILIZING LEGS) +664 KGS
- DUAL POWER FITTED +1500 KGS
- HARDOX LINERS IN FEEDER BIN +413 KGS

CUBIC CAPACITY - 145 M³

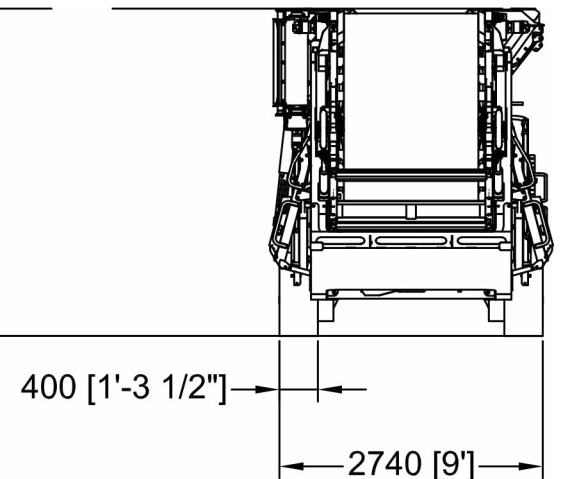
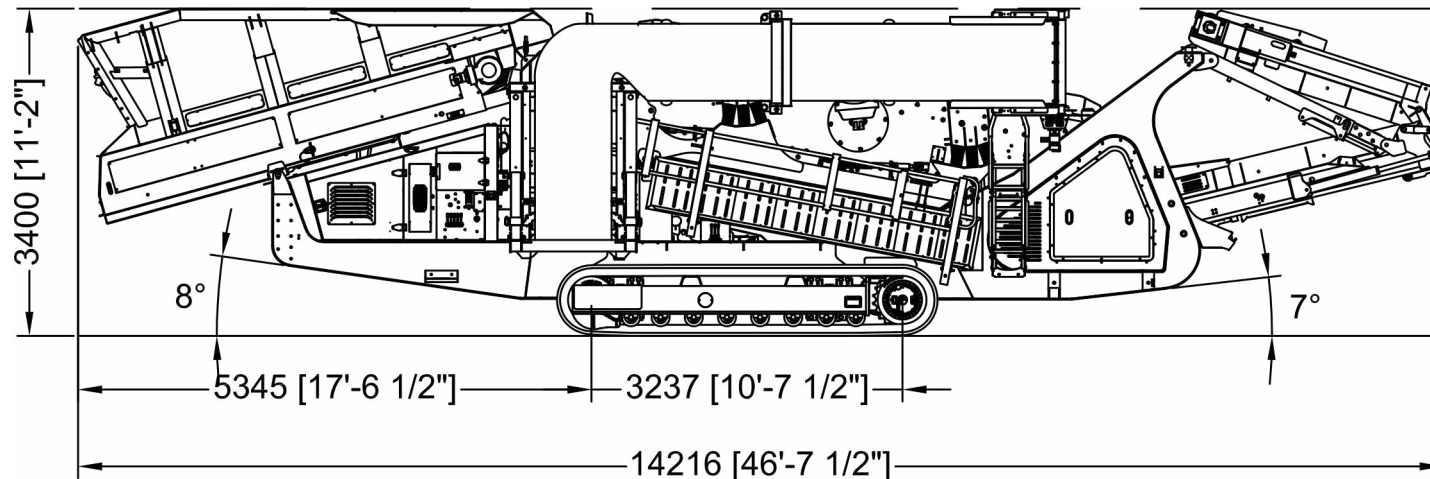
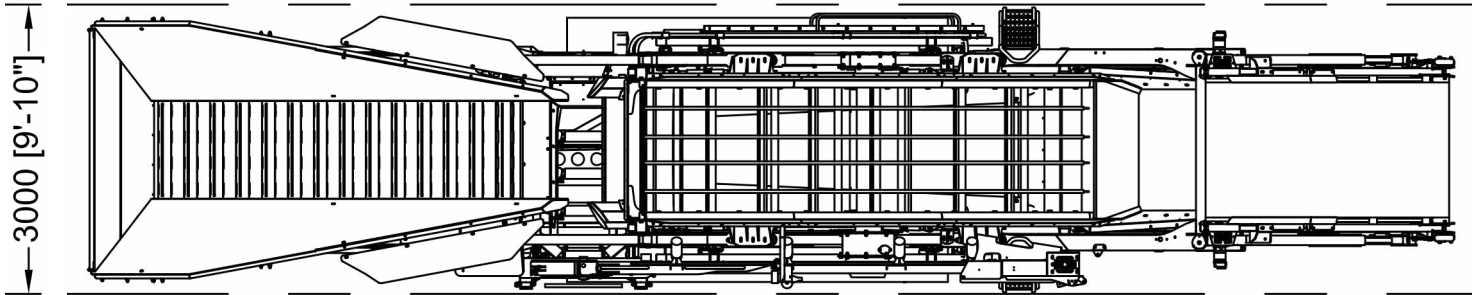

All specifications subject to change without prior notice

2-WAY SPLIT
WORKING ARRANGEMENT
HOPPER EXTENSIONS FITTED

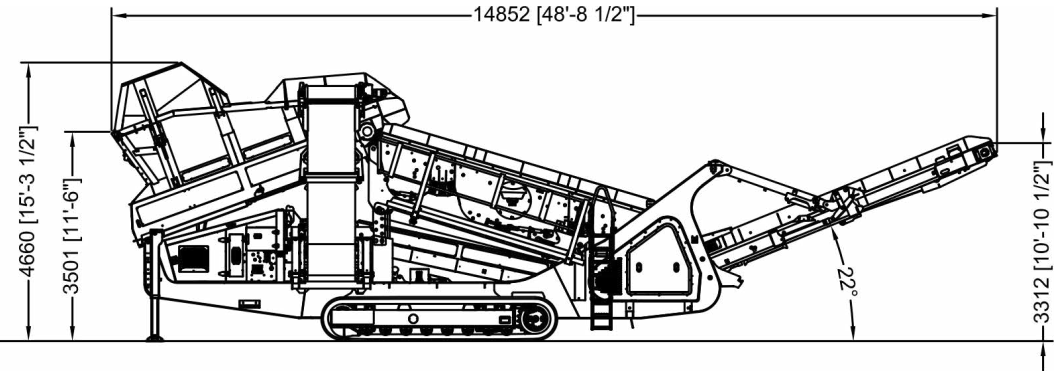
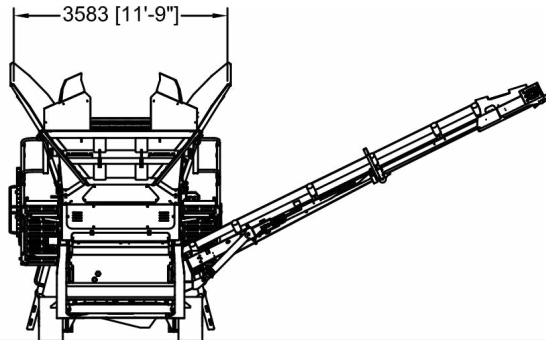

3-WAY SPLIT
WORKING ARRANGEMENT
HOPPER EXTENSIONS FITTED

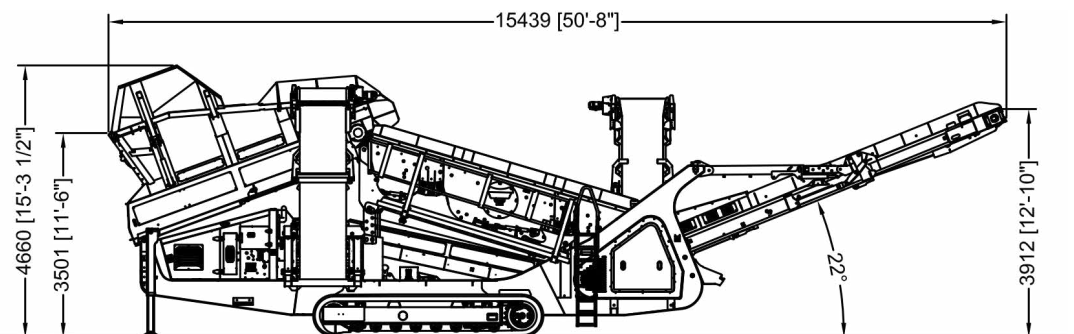
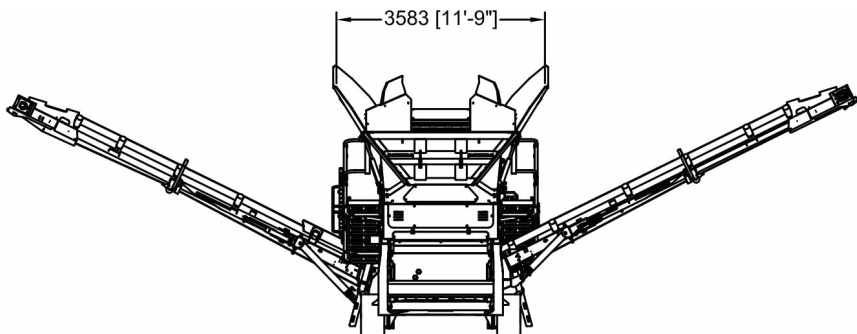

All specifications subject to change without prior notice

2-WAY SPLIT
WORKING ARRANGEMENT
HOPPER EXTENSIONS FITTED

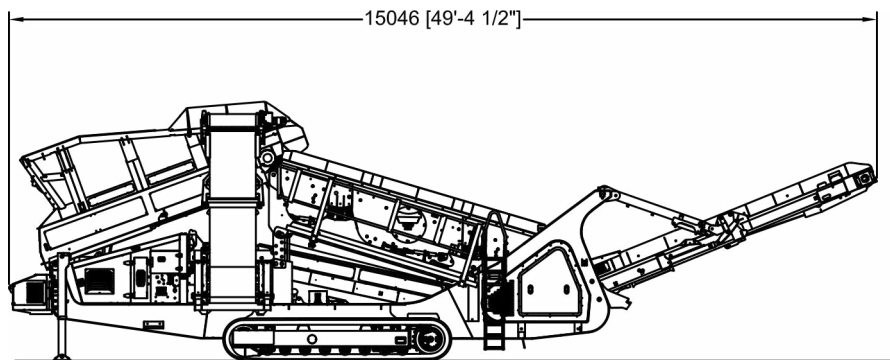

3-WAY SPLIT
WORKING ARRANGEMENT
HOPPER EXTENSIONS FITTED

