

**OUT**

# DS2223RTP

**Rough terrain scissor lift**

## LIST OF STANDARD EQUIPMENT

- Automatic stabilizers to work at height
- Crushing protection
- Self-locking door on the platform
- Speed limit at maximum height
- Platform load sense system
- Automatic braking system
- Non-marking tyres
- Tilt indicator with alarm
- Warning siren during lowering and dual flashing LED light
- Safety bracket for maintenance operations
- Horn
- Emergency stop button
- Emergency lowering
- Anchoring eyebolts
- Onboard diagnostics system
- Hour counter
- Proportional controls
- Fold-down guardrails
- Power to platform
- Explosion-proof tubing system
- Motion Alarm
- Integrated holes for fork transport
- Tie-down and lifting points
- Dual slide-out platform extension deck
- Four-wheel drive
- Four-wheel steering
- Self-weight lowering system
- Manual emergency brake release
- Hydraulic oil cooling system
- Anti-restart Engine Protection

**LOGISTICS****CONSTRUCTION**

## DS2223RTP

Load capacity		750 kg
Load capacity on extended platform		750 kg
Max no. occupants		4
Working height	A	22 m
Platform floor height	B	20 m
Overall length (with outriggers)	C	4.95 m
Overall width	D	2.46 m
Overall height (rails up)	E	3.86 m
Transport height (rails down)	F	3.00 m
Platform size (length/width)		4.59 m x 2.25 m
Platform extension size	G	2.7 m
Ground clearance		40 cm
Wheelbase	H	3.3 m
Turning radius (inside/outside)		1.25 m / 3.4 m
Engine		Deutz D2.9 L4 Stage V - 36.4 kW 2600 rpm
Drive motor		-
Lifting motor		-
Travel speed (stowed)		4.7 km/h
Travel speed (raised)		0.4 km/h
Gradeability		40%
Maximum working slope		2°/3°
Batteries		-
Integrated charger		-
Hydraulic tank		150 l
Diesel tank		100 l
Tyres		36×14-20
Weight (with outriggers)		13,000 kg



Automatic stabilizers



Non-marking solid tyres

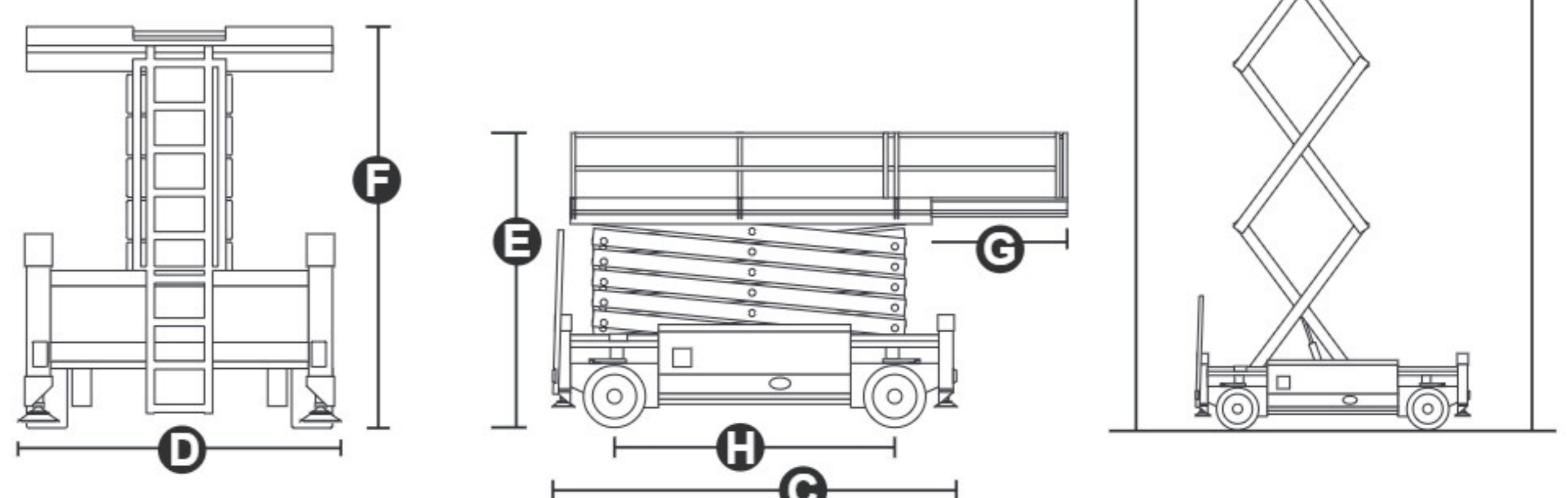

### STANDARDS MET: EN 280-1, ANSI/SAIA A92.20

The data given in this brochure are provided for information purposes and are subject to change without prior notice. All images are purely guideline and might not give an exact representation of the product.