

THIS DRAWING, THE COMPREHENDED INFORMATION INCLUDED, IS THE PROPERTY OF CONVER BV. THIS DRAWING SHALL NEITHER BE TRANSFERRED TO ANY THIRD PARTY, NEITHER BE COPIED IN WHOLE OR IN PART, NOR BE USED FOR ANY OTHER PURPOSE THAN DIRECTLY RESULTING FROM CONVER BY ORDERS

U:\MB\MaaiBoten\C485IIF\000; Samenstelling\50240; C485IIF Samenstelling

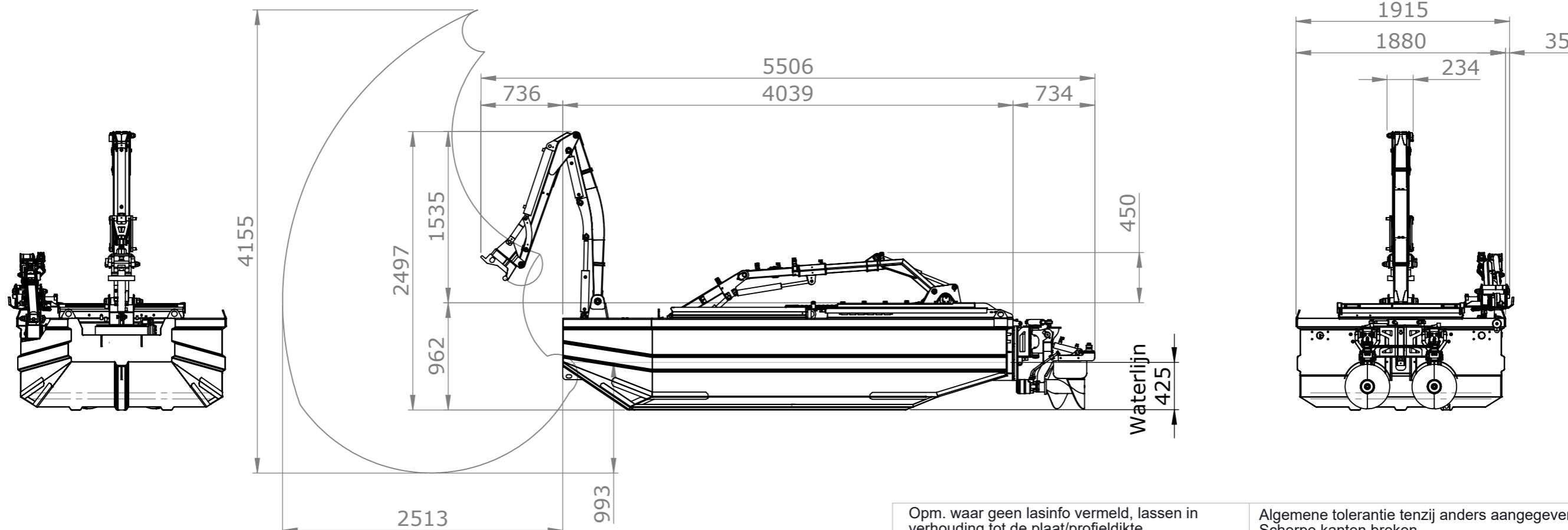
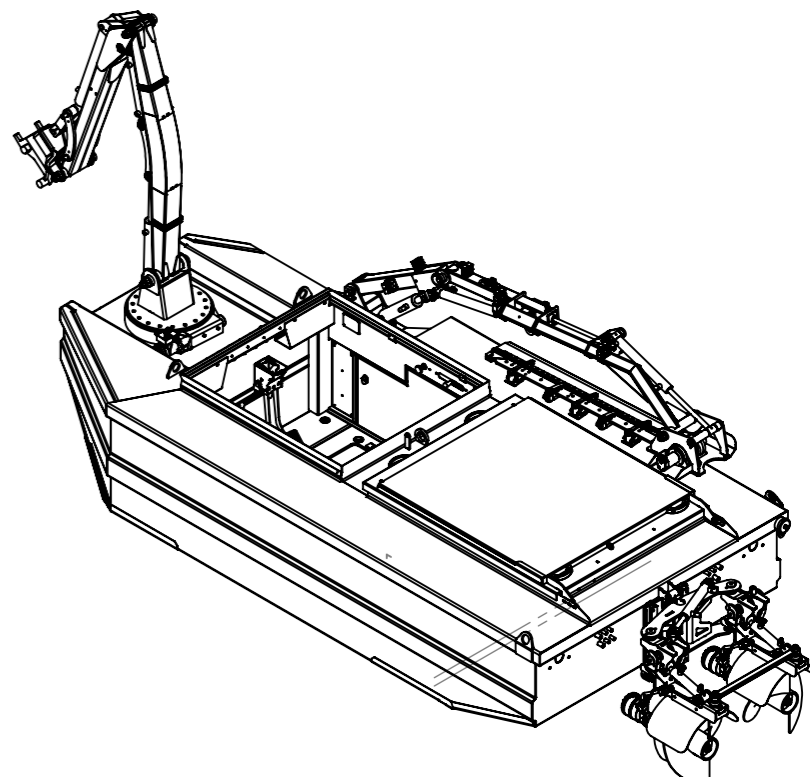
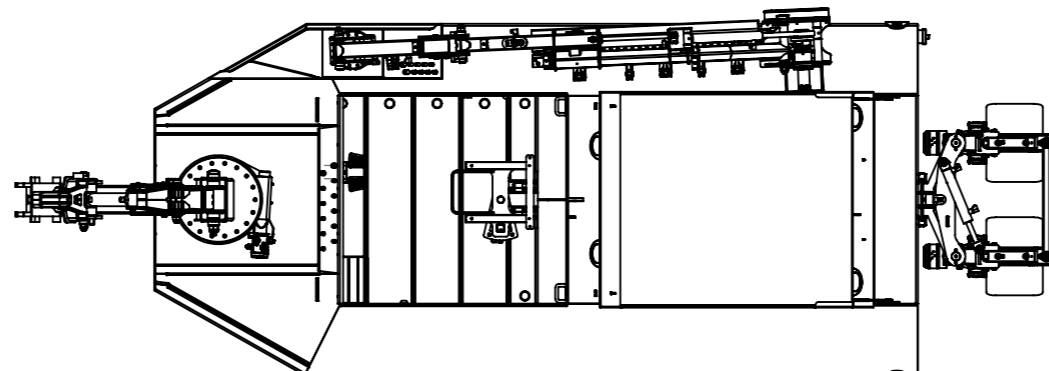
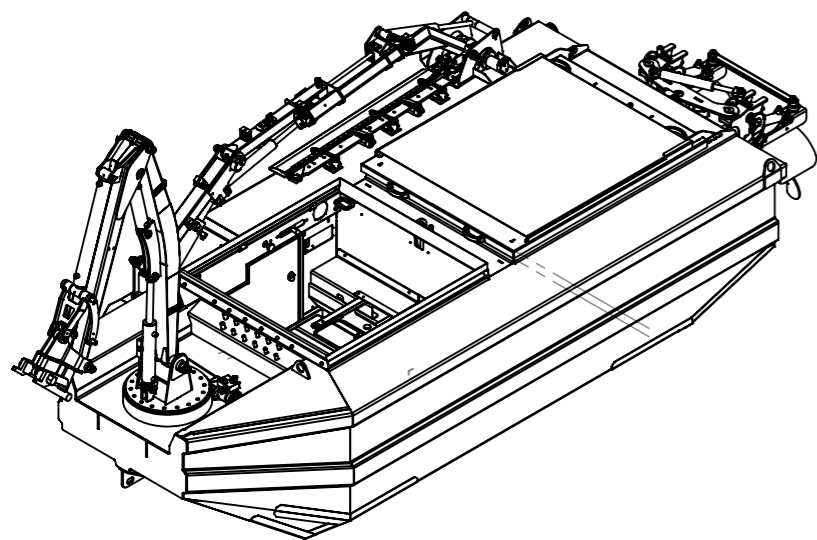

Opm. waar geen lasinfo vermeld, lassen in verhouding tot de plaat/profiel dikte a=minimaal 0,7 x de dikte van de dunste plaat

Algemene tolerantie tenzij anders aangegeven $\pm 0,5\text{mm}$ 6,3
 Scherpe kanten breken

REVISIE					
CONVER		MATERIAAL	GEWICHT	BEHANDELING	
Conver BV Industrieweg 18 4283 GZ Giessen 0183-447272 info@conver.com www.conver.com			1564.33 Kg		
		BENAMING			
		C485IIF Maaiboot			
CONTROLE	EENHEID	mm	SERIE NO.	TEKENING NUMMER	
TEKENAAR	ES	18-11-2016	SCHAAL	1:40	BLAD
				1 van 1	50240-100

